

REVISION RECORD				
REV	ECN	DESCRIPTION	DRFT	DATE

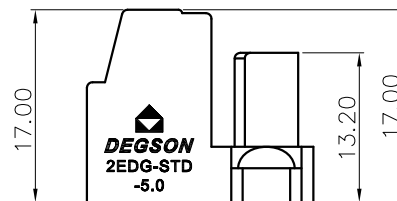
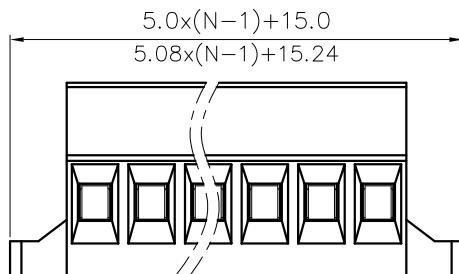
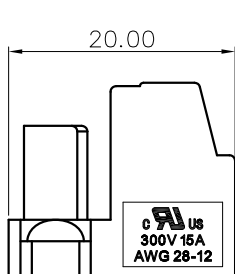
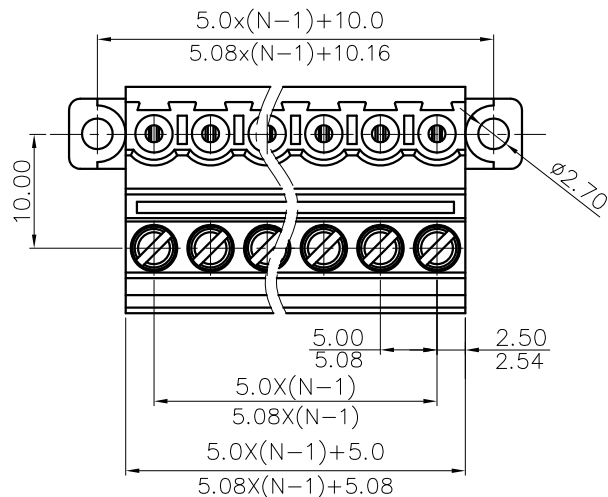

NOTES1:

UL Standard

- 1.Rated voltage/current : 300V / 15A
- 2.Withstanding voltage : AC1600V/1Min.
- 3.Torque value : M2.5 , 3.54Lb.in
- 4.Wire range : 28~12AWG

IEC Standard

1. Pollution degree	2
Overvoltage category	III
Rate impulse voltage(KV)	4.0KV
Rate voltage(V)	250V
Rate current(A)	24A

- 2.Torque value : M2.5 , 0.4N·m
- 3.Wire range : 1.0~2.5mm²

NOTES2:

- 1.Dimension shall be interpreted per ASME Y14.5-2009
- 2.Pitch : 5.0/5.08mm, Poles : N=02~24P
- 3.Stripping length : 8~9mm
- 4.Operating temperature: -40°C~+105°C
- 5.Undimensioned tolerances:

Pitch range in mm		Nominal dimension range in mm					-	∩	∠
TO	Over	Over	Over	Over	Over	Over	0.1/10		
6	10	10	30	60	100	150	<		
±0.15	±0.20	±0.30	±0.30	±0.50	±0.70	±1.00	±1.30	±2'	

6.RoHS Compliance

2EDG-STD - 5.08 - XXP - 1Y - 00A (H)
 (Series No.) (Pitch) (Poles) (Single Pitch) (Color):1.(Grey)
 2.(Blue)
 3.(Black)
 4.(Green)
 5.(Orange)
 6.(Red)
 7.(Transparent)
 8.(Yellow)
 9.(White)
 (RoHS)
 00A-(Standard)

DETACHED LISTS	PART NO.:	/			
	APPD:	/			
	CHKD:	/			
	DRFT:	/			
NAME:		NINGBO DEGSON ELECTRICAL CO., LTD			
TITLE:		CUSTOMER DRAWING			
DRAWING NO.:		/			
THIRD ANGLE PROJECTION		MM (INCH)	DO NOT SCALE DRAWING	SCALE	
REV		DO			
SHEET		1/1			
SCALE		1:1			