



SPECIFICATION FOR LCD MODULE

MODULE NO: YB-TG19201080C02A-C-A0

Doc.Version:01

Customer Approval:

<input type="checkbox"/> Accept	<input type="checkbox"/> Reject
---------------------------------	---------------------------------

YEEBO	NAME	SIGNATURE	DATE
Prepare	Electronic Engineer	袁江敏	2019/4/3
Check	Mechanical Engineer	李林	2019/4/3
Verify		陈长吉 谭毅	2019/4/3
Approval		Sumray	2019/4/3

APPROVAL FOR SPECIFICATIONS ONLY

APPROVAL FOR SPECIFICATIONS AND SAMPLE

WIMRD005-02-C



2. Table of Contents:

NO	CONTENTS	PAGE
1	Revision History	1
2	Table of Contents	2
3	Module Numbering System	3
4	General Specification	4
5	LCM drawing	5
6	Interface Pin Assignment	7
7	Electrical Characteristics	11
8	Optical Characteristics	15
9	Backlight	19
10	Reliability Test Items	21
11	Specification of Quality Assurance	29
12	Handling Precaution	30
13	Guarantee	30



3. Module Numbering System:

(Example)

YB- TG 7201280 C 17 A -C - A A0

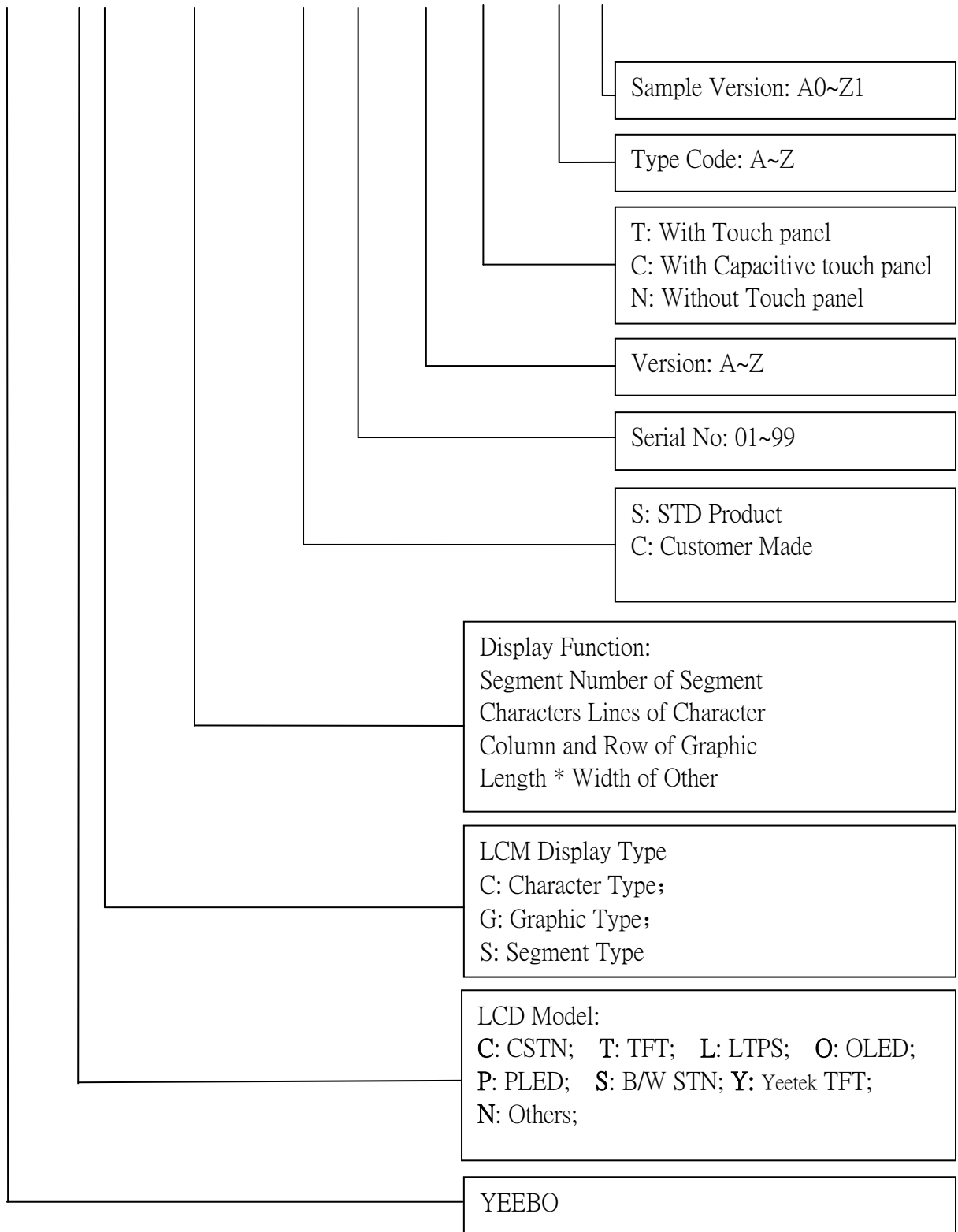



4. General Specification:

ITEM	CONTENTS
Assembly Module Size	294.60(W) * 196.50(H) * 7.70(T) mm
Display Size(Diagonal)	11.6 inch
Display Format	1920(RGB)*1080 Pixels
Active Area	256.32(W) * 144.18(H) mm
Pixel Pitch	0.1335 * 0.1335 mm
LCD Type	Normally black, Transmissive
TFT Driver element	a-SI TFT active matrix
Surface treatment	Anti-Glare
Color arrangement	RGB-stripe
TFT interface	EDP
LCM power consumption	6.6W
View Direction	ALL
CTP IC	ILI2510
CTP Interface	I ² C
Weight(g)	≈550g
Firmware	8970_20190125.hex
Test Configuration	8970_20190123_0xff50.dat



5. CTP+LCM drawing:

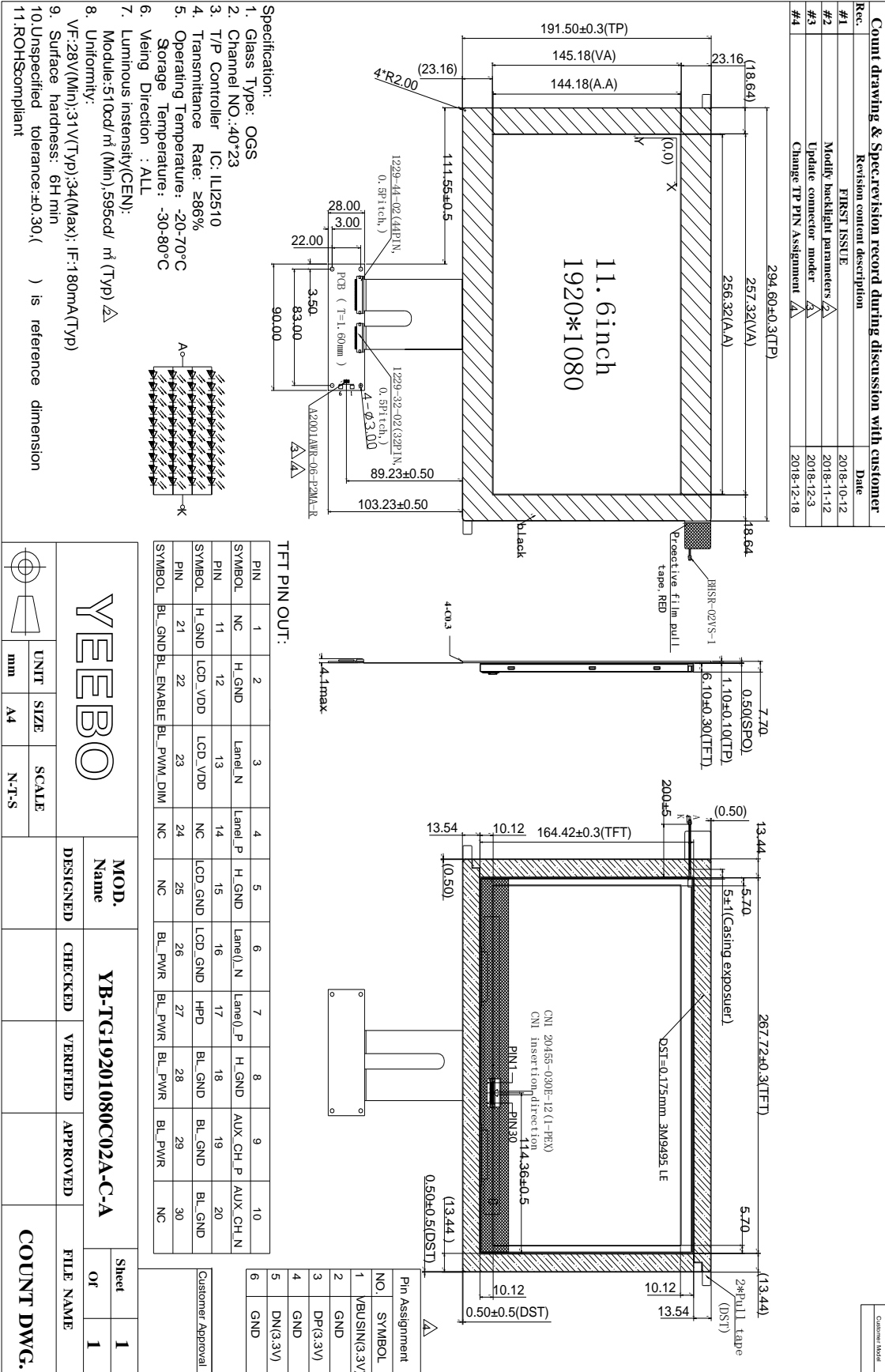

6.interface Pin Assignment

6-1. TFT FPC Connector is used for the module electronics interface. The recommended model is

20455-030E-12 (I-PEX) manufactured by Hirose.

Pin No.	Symbol	I/O	Function	Remark
1	NC	-	No connect	
2	H_GND	P	High Speed Ground	
3	Lane1_N	I	Complement Signal Link Lane 1	
4	Lane1_P	I	True Signal Link Lane 1	
5	H_GND	P	High Speed Ground	
6	Lane0_N	I	Complement Signal Link Lane 0	
7	Lane0_P	I	True Signal Link Lane 0	
8	H_GND	P	High Speed Ground	
9	AUX_CH_P	I	True Signal Auxiliary Channel	
10	AUX_CH_N	I	Complement Signal Auxiliary Channel	
11	H_GND	P	High Speed Ground	
12-13	LCD_VCC	P	LCD logic and driver power(3.3V)	
14	NC	-	No connect	
15-16	LCD_GND	P	LCD logic and driver ground	
17	HPD	I	HPD Signal	
18-30	NC	-	No connect	

I: input; O: output; P: Power or Ground(0V).

Note:

CN1 pin 1 position





6-2 . CTP Pin Assignment

Pin No.	Symbol	I/O	Function
1	VBUSIN	P	USB Supply Power
2	GND	P	Ground
3	DP	I/O	USB Data Positive
4	GND	P	Ground
5	DN	I/O	USB Data Positive
6	GND	P	Ground



7. Electrical Characteristics

7.1 Absolute Maximum Ratings

Stresses beyond those listed under "Absolute Maximum Ratings" may cause permanent damage to the device. These are for stress ratings. Functional operation of the device at these or any other conditions beyond those indicated in the operational sections of the specifications is not implied. Exposure to absolute maximum rating conditions for extended periods may remain possibility to affect device reliability.

Table 7-1: Absolute Maximum Ratings

Parameter	Symbol	Min	Max	Unit
Chip power input	V_{DD}	-0.3	3.6	V
V_{DD3A} to GND	V_{DD3A}	-0.3	3.6	V
V_{DD3D} to GND	V_{DD3D}	-0.3	3.6	V
V_{DD10} to GND	V_{DD10}	-0.3	3.6	V
V_{DD16} to GND	V_{DD16}	-0.3	1.65	V
V_{GH} to GND	V_{GH}	-0.3	32	V
V_{TX} to GND	V_{TX}	-0.3	32	V
ESD Susceptibility HBM (Human Body Mode)(Note 1)	HBM		4000	V
ESD Susceptibility MM (Machine Mode)	MM		400	V

Note 1: Devices are ESD sensitive. Handling precaution is recommended.

7.2 Recommended Operating Conditions

Table 7-2: Recommended Operating Conditions

Parameter	Symbol	Min	Max	Unit
V_{DD} to GND input power supply voltage	V_{DD}	3.14	3.46	V
V_{DD3A} to GND	V_{DD3A}	3.14	3.46	V
V_{DD3D} to GND	V_{DD3D}	3.14	3.46	V
V_{DD10} to GND	V_{DD10}	1.8	3.46	V
V_{GH} to GND	V_{GH}	-0.3	32	V
V_{TX} to GND	V_{TX}	-0.3	32	V
Operating Ambient Temperature Range	TA	-20	85	°C
Operating Junction Temperature Range	TJ	-40	125	°C
Storage Ambient Temperature Range	T _{ST}	-40	150	°C

Note: The device is not guaranteed to function outside its operating conditions.

7.3 DC Characteristics

Table 7-3: Input Power Supply

(VDD3A = VDD3D = 3.3V, Room Temperature)

Item	Symbol	Min	Typ.	Max	Unit	Condition
USB 3.3V input power supply voltage	V_{DD}	3.14	3.3	3.46	V	@ USB
Digital input power supply voltage*	V_{DD3D}	3.14	3.3	3.46	V	
Analog input power supply voltage	V_{DD3A}	3.14	3.3	3.46	V	
I/O input power supply voltage*	V_{DDIO}	1.8	3.3	3.46	V	

*If VDDIO & VDD3D is not supplied power, there is risk of I/O pin with current leakage

Table 7-4: DC Characteristics

(VDD3A = VDD3D = 3.3V, Room Temperature)

Item	Symbol	Min	Typ.	Max	Unit	Condition
Operation current	I_{op}		100		mA	Active Mode / 21.5°
Input Low Voltage	V_{L1}	0		$0.3V_{DDIO}$	V	
Input High Voltage	V_{H1}	$0.6V_{DDIO}$		$V_{DDIO}+0.5$	V	
Hysteresis voltage	V_{HY}		$0.2V_{DDIO}$		V	
Input Low Voltage, XT_In	V_{L2}	0		0.6	V	$V_{DDIO}=3.3V$
Input High Voltage, XT_In	V_{H2}	2.6		$V_{DDIO}+0.2$	V	$V_{DDIO}=3.3V$
Negative going threshold, /Reset	V_{ILS}	0		$0.2V_{DDIO}$	V	
Positive going threshold, /Reset	V_{HIS}	$0.6V_{DDIO}$		$V_{DDIO}+0.5$	V	
Output High Voltage	V_{OH}	$0.7V_{DDIO}$			V	$V_{DDIO}=3.3V$, $I_{OH}=8mA$
Output Low Voltage	V_{OL}			$0.3V_{DDIO}$	V	$V_{DDIO}=3.3V$, $I_{OL}=10mA$

Table 7-5:USB DC Characteristics

Item	Symbol	Min	Typ.	Max	Unit	Condition
Input Low	V_{IL}			0.8	V	
Input High (driven)	V_{IH}	2.0			V	
Differential input sensitivity	V_{DI}	0.2			V	(D+) – (D-)
Differential common-mode range	V_{CM}	0.8		2.5	V	Includes V_{DI} range
Single-ended receiver threshold	V_{SE}	0.8		2.0	V	
Receiver hysteresis	V_{RH}		200		mV	
Output low (driven)	V_{OL}	0		0.3	V	
Output high (driven)	V_{OH}	2.8		3.6	V	
Output signal cross voltage	V_{CRS}	1.3		2.0	V	
Pull-up resistor	R_{PU}	1.425		1.575	k Ω	
Pull-down resistor	R_{PD}	14.25		15.75	k Ω	
Termination Voltage for upstream port pull up (RPU)	V_{TRM}	3.0		3.6	V	

Table 7-6:Crystal Characteristics

Item	Symbol	Min	Typ.	Max	Unit	Condition
Input clock frequency	f_{XIN}		12		MHz	External crystal

7.4 I2C AC Characteristics

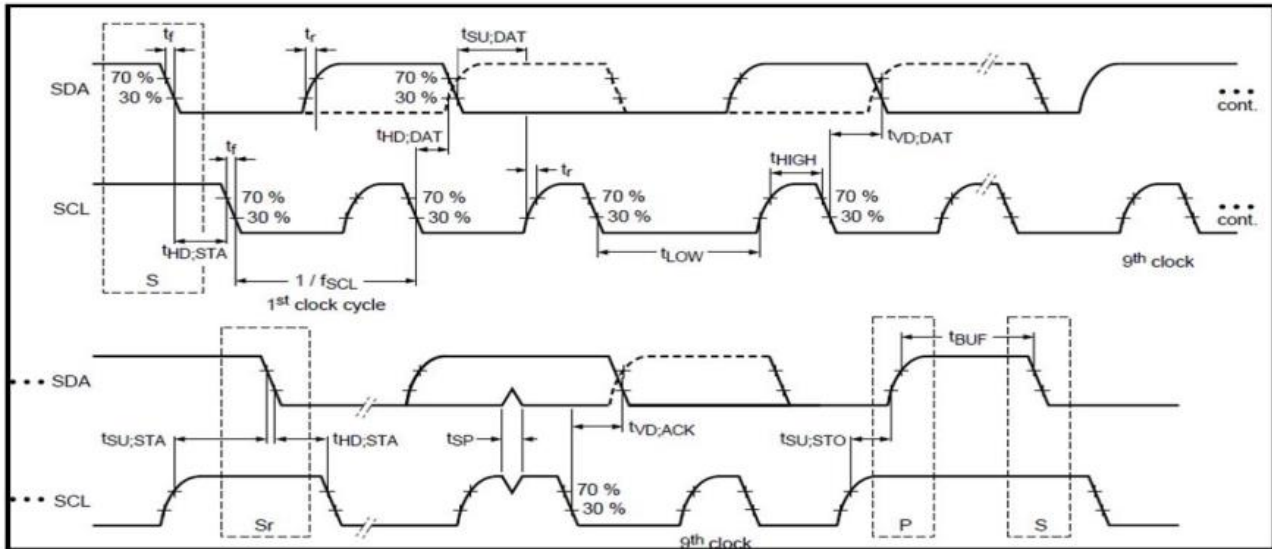

Table 7-7: I2C DC Characteristics

Parameter	Symbol	Standard-mode		Fast-mode		Unit
		Min	Max	Min	Max	
SCL clock frequency	f_{SCL}	0	100	0	400	kHz
Hold time START condition	$t_{HD,STA}$	4.0	-	0.6	-	us
LOW period of the SCL clock	t_{LOW}	4.7	-	1.3	-	us
HIGH period of the SCL clock	t_{HIGH}	4.0	-	0.6	-	us
Set-up time for a repeated START condition	$t_{SU,STA}$	4.7	-	0.6	-	us
Data hold time	$t_{HD,DAT}$	300	-	300	-	ns
Data set-up time	$t_{SU,DAT}$	250	-	100	-	ns
Rise time of both SDA and SCL signals (30% to 70%)	t_r	-	1000	20	300	ns
Fall time of both SDA and SCL signals (70% to 30%)	t_f	-	300	20	300	ns
Set-up time for STOP condition	$t_{SU,STO}$	4.0	-	0.6	-	us
Bus free time between a STOP and START condition	t_{BUF}	4.7	-	1.3	-	us
Capacitive load for each bus line	C_b	-	400	-	400	pF
Noise margin at the LOW level for each connected device	V_{NL}	$0.1V_{DD}$	-	$0.1V_{DD}$	-	V
Noise margin at the HIGH level for each connected device	V_{NH}	$0.2V_{DD}$	-	$0.2V_{DD}$	-	V

*SCL = I2C Host must to support clock stretching mode for using 400 kHz.

8. Typical Operation Conditions

Test condition: GND=0V, T_A=25 °C

Item	Symbol	Values			Unit	Remark
		Min.	Typ.	Max.		
Power voltage	LCD_VCC	3.0	3.3	3.6	V	
Current for Driver	LCD_VCC	-	280	-	MA	
Voltage for LED Backlight	V _L	24.5	27	31	V	Note 1
Current for LED Backlight	I _L	-	200	-	mA	
LED life time	-	50,000	-	-	Hr	Note 2

Note1: V_L=27V, I_L=200mA (Backlight circuit: 9series connection, 5 parallel connection), the ambient temperature is 25°C.

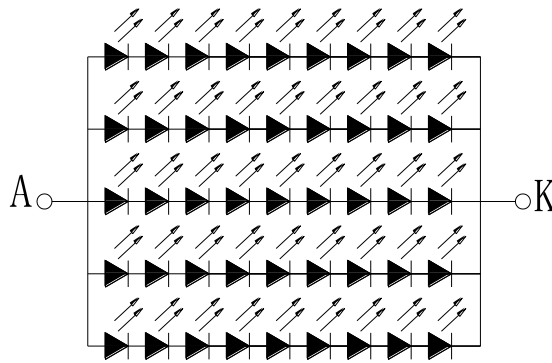

Fig. 3-1 LED test circuit diagram

Note 2: The “LED life time” is defined as the module brightness decrease to 50% original brightness at T_a=25°C and I_L =200mA . The LED lifetime could be decreased if operating I_L is larger than 225 mA.

8.1 Power Sequence

Ta=+25°C

DC Electrical Characteristics						
Parameter	Symbol	Min.	Typ.	Max.	Unit	Remark
+3.3V supply voltage	VDD	+3.0	+3.3	+3.6	V	[Note 6-1-1]
Current dissipation	IDD	-	(212)	(364)	mA	[Note 6-1-2]
Inrush Current	Irush	-	-	TBD	A	[Note 6-1-3]
Permissible input ripple voltage	V _{RP}	-	-	100	mVp-p	VDD=+3.3V
eDP HPD Signal Characteristics						
Parameter	Symbol	Min.	Typ.	Max.	Unit	Remark
HPD High level output voltage	VOH _{HPD}		VDD-0.1	-		
HPD Low level output voltage	VOL _{HPD}	-	0			
eDP AUX Channel Characteristics						
Parameter	Symbol	Min.	Typ.	Max.	Unit	Remark
Unit Interval for AUX channel	UI _{AUX}	0.4	0.5	0.6	μS	
Peak-to-peak voltage at TP1	V _{AUX-DIFF-pp}	0.32	-	1.36	V	
AUX DC Common mode Voltage	V _{AUX-DC-CM}	0	-	2.0	V	
AUX Short current limit	I _{AUX-SHORT}	-	-	90	mA	
AUX CH termination Resistor	R _{AUX-TERM}	-	100	-	Ω	Differential input
AUX AC coupling capacitor	C _{AUX}	75	-	200	nF	
Number of pre-charge pulses	Pre-charge pulses	10	-	16	-	
eDP Main Link Receiver Characteristics						
Parameter	Symbol	Min.	Typ.	Max.	Unit	Remark
Link clock down spreading	Down_Spread_Amplitude	0		0.5	%	
Differential Peak-to-peak Input Voltage at Rx package pins	V _{RX-DIFFp-p}	120	-	1200	mV	
Differential Return Loss at 1.35GHz at Rx package pins	RL _{RX-DIFF}	9	-	-	dB	
Differential termination resistance	R _{RX-TERM}	-	100	-	Ω	
RX short circuit Current Limit	I _{RX-SHORT}	-	-	50	mA	
Lane Intra-pair Skew at RX package pins	T _{RX-SKEW-INTRA-PAIR-High-Bit-Rate}	-	-	TBD	ps	

ON-OFF conditions for supply voltage:

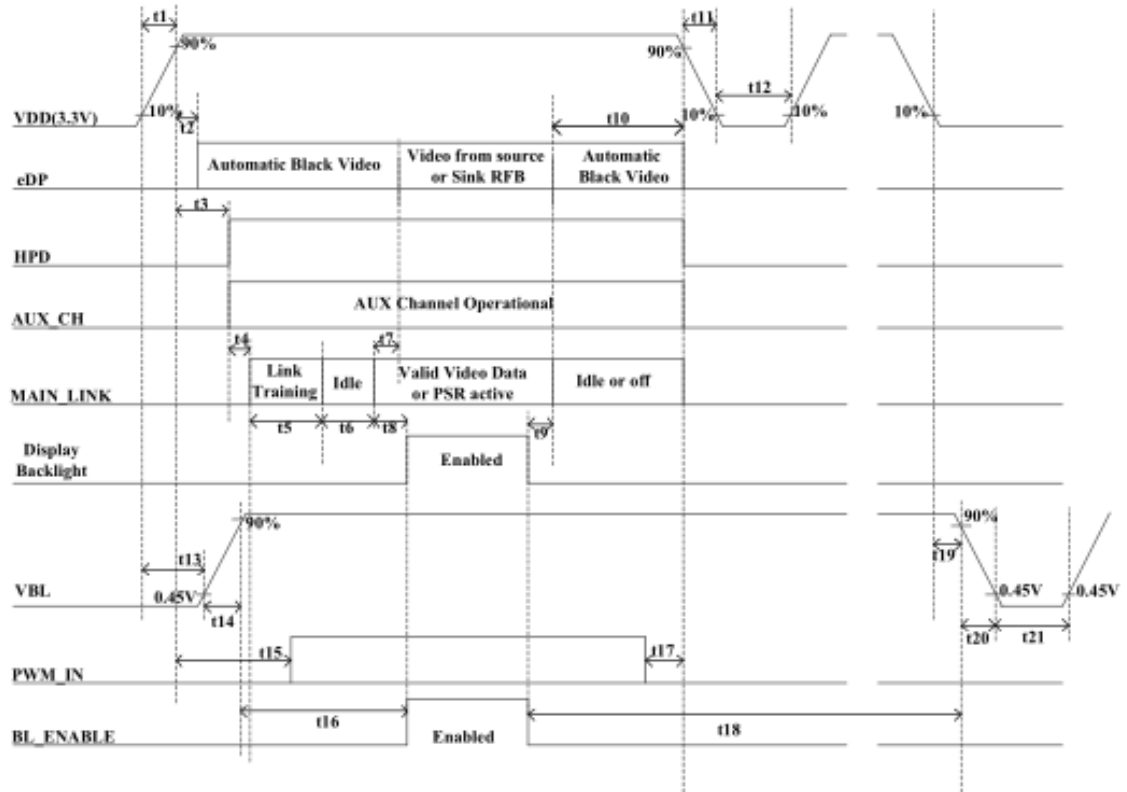

[Note] Do not keep the interface signal high-impedance or unusual signal when power is on.

Symbol	Min	Max	Unit	Note
t1	(0.5)	(10)	ms	
t2	0	100	ms	
t3	0	(100)	ms	
(t4)	-	-	ms	
(t5)	-	-	ms	
(t6)	-	-	ms	
(t7)	(0)	(50)	ms	
(t8)			ms	
(t9)			ms	
(t10)	(0)	(500)	ms	
t11	(1)	50	ms	[Note1]
t12	500	-	ms	
(t13)	-	-	ms	
t14	0.5	10	ms	
t15	(100)		ms	
(t16)	-	-	ms	
t17	0	-	ms	
(t18)	-	-	ms	
t19	-	-	ms	
t20	(0.1)	-	ms	
t21	(100)		ms	

8.2 Signal Timing Characteristics

Parameter	Symbol	Min.	Typ.	Max.	Unit	Remark
Clock	Frequency	-	138.5	-	MHz	[Note7-1-1]
Data enable signal	Horizontal period	-	2080	-	clock	
			15.02		μ s	
	Horizontal period (High)	-	1920	-	clock	
	Vertical period	-	1111	-	line	
		-	16.685	-	ms	
	Vertical period (High)	-	1080	-	line	

[Note 7-1-1] In case of using the long vertical period, the deterioration of display quality, flicker, etc., may occur.

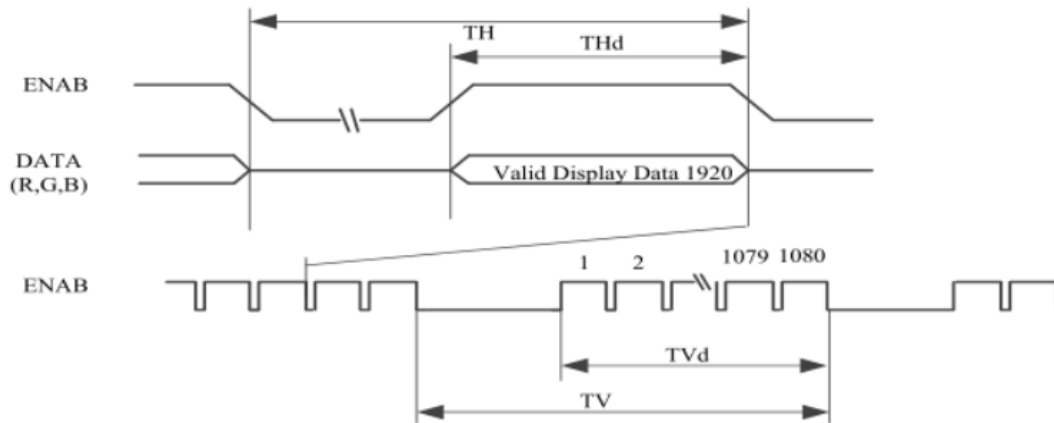

9. Optical Specifications

Item	Symbol	Condition	Values			Unit	Remark
			Min.	Typ.	Max.		
Viewing angle (CR≥ 10)	θL	Φ=180° (9 o'clock)	80	89	-	degree	Note 1
	θR	Φ=0°(3 o'clock)	80	89	-		
	θT	Φ=90° (12 o'clock)	80	89	-		
	θB	Φ=270° (6 o'clock)	80	89	-		
Response time	TON+ TOFF	Normal θ = Φ=0°	-	25	-	msec	Note 2
Contrast ratio	CR		700	1000	-	-	Note 3
Color chromaticity	WX		0.27	0.31	0.35	-	Note 4
	WY		0.29	0.33	0.37	-	Note 5 Note 6
Luminance	L		510	595	-	cd/m ²	Note 6
Luminance uniformity	YU		70	75	-	%	Note 7

The test systems refer to Note 2.

Note 1: Definition of viewing angle range

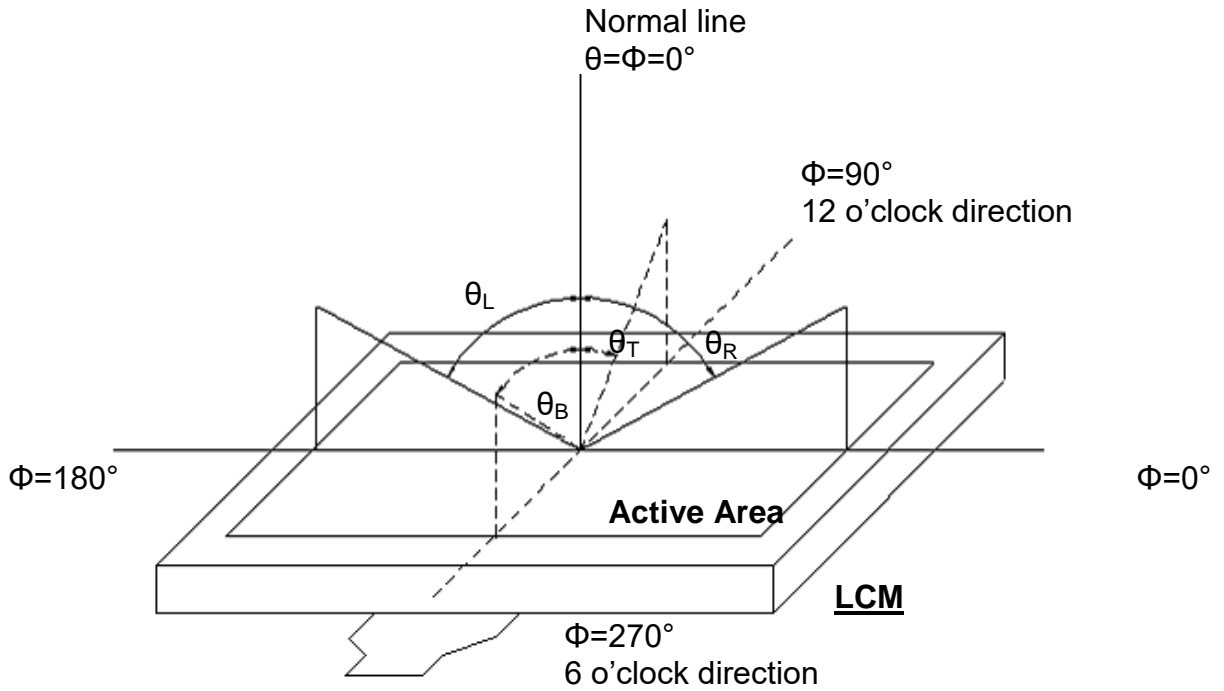

Fig. 4-2 Definition of viewing angle

Note 2: Definition of Response time

The response time is defined as the LCD optical switching time interval between "White" state and "Black" state. Rise time (T_{ON}) is the time between photo detector output intensity changed from 90% to 10%. And fall time (T_{OFF}) is the time between photo detector output intensity changed from 10% to 90%.

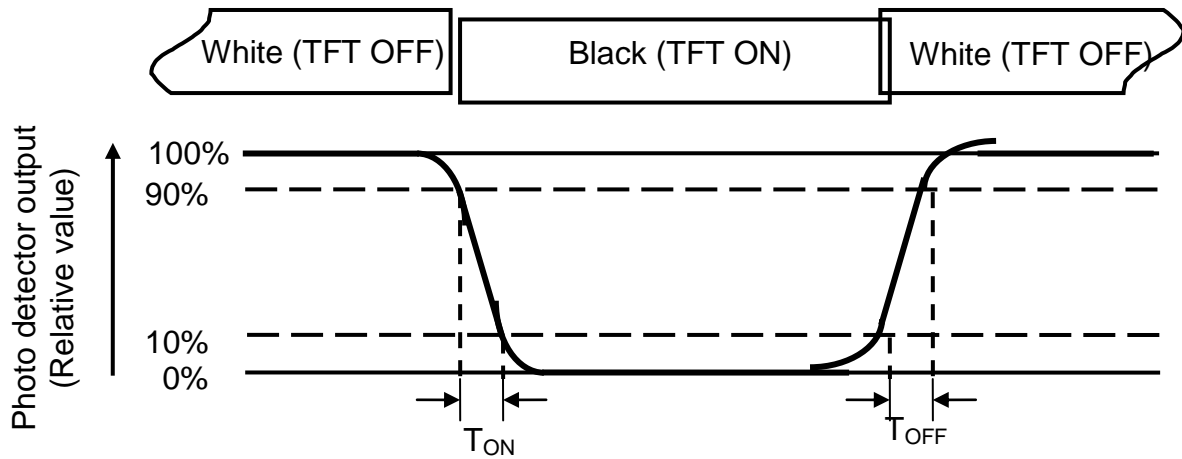

Fig. 4-3 Definition of response time

Note 3: Definition of contrast ratio



Note 4: Definition of optical measurement system.

The optical characteristics should be measured in dark room. After 30 minutes operation, the optical properties are measured at the center point of the LCD screen. (Viewing angle is measured by ELDIM-EZ contrast/Height :1.2mm, Response time is measured by Photo detector TOPCON BM-7, other items are measured by BM-5A/ Field of view: 1° /Height: 500mm.) or CA-210.

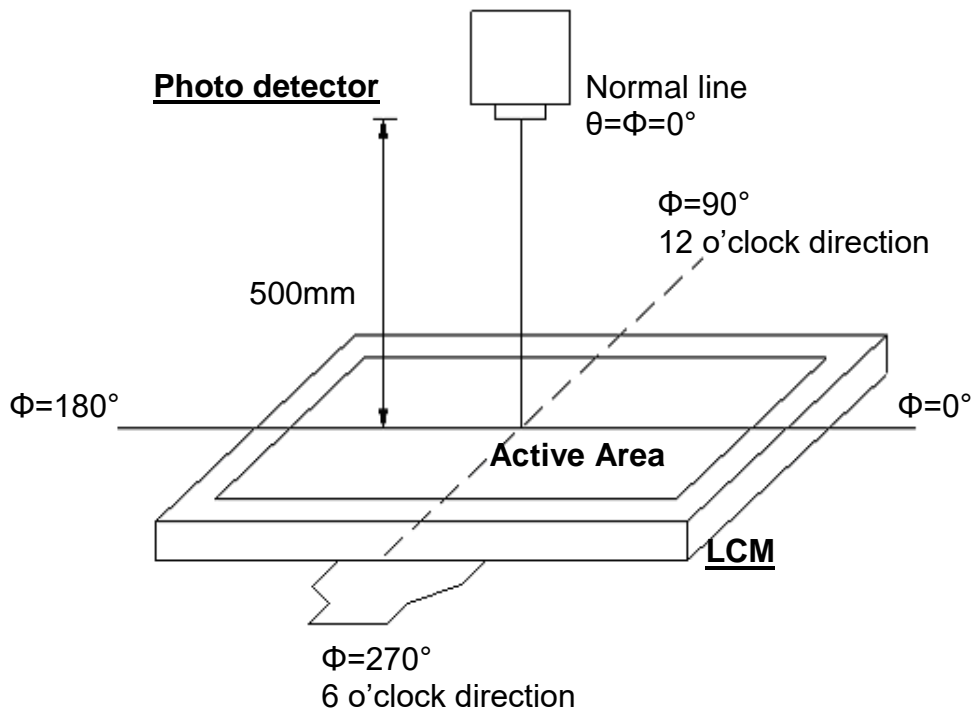

Fig. 4-4 Optical measurement system setup

Note 5: Definition of color chromaticity (CIE1931)

Color coordinates measured at center point of LCD.

Note 6: All input terminals LCD panel must be ground while measuring the center area of the panel. The LED driving condition is $I_L = 200\text{mA}$.

Note 7: Definition of Luminance Uniformity

Active area is divided into 9 measuring areas (Refer to Fig. 4-5).

Every measuring point is placed at the center of each measuring area.

$$\text{Luminance Uniformity (Yu)} = \frac{B_{min}}{B_{max}}$$

L-----Active area length W----- Active area width

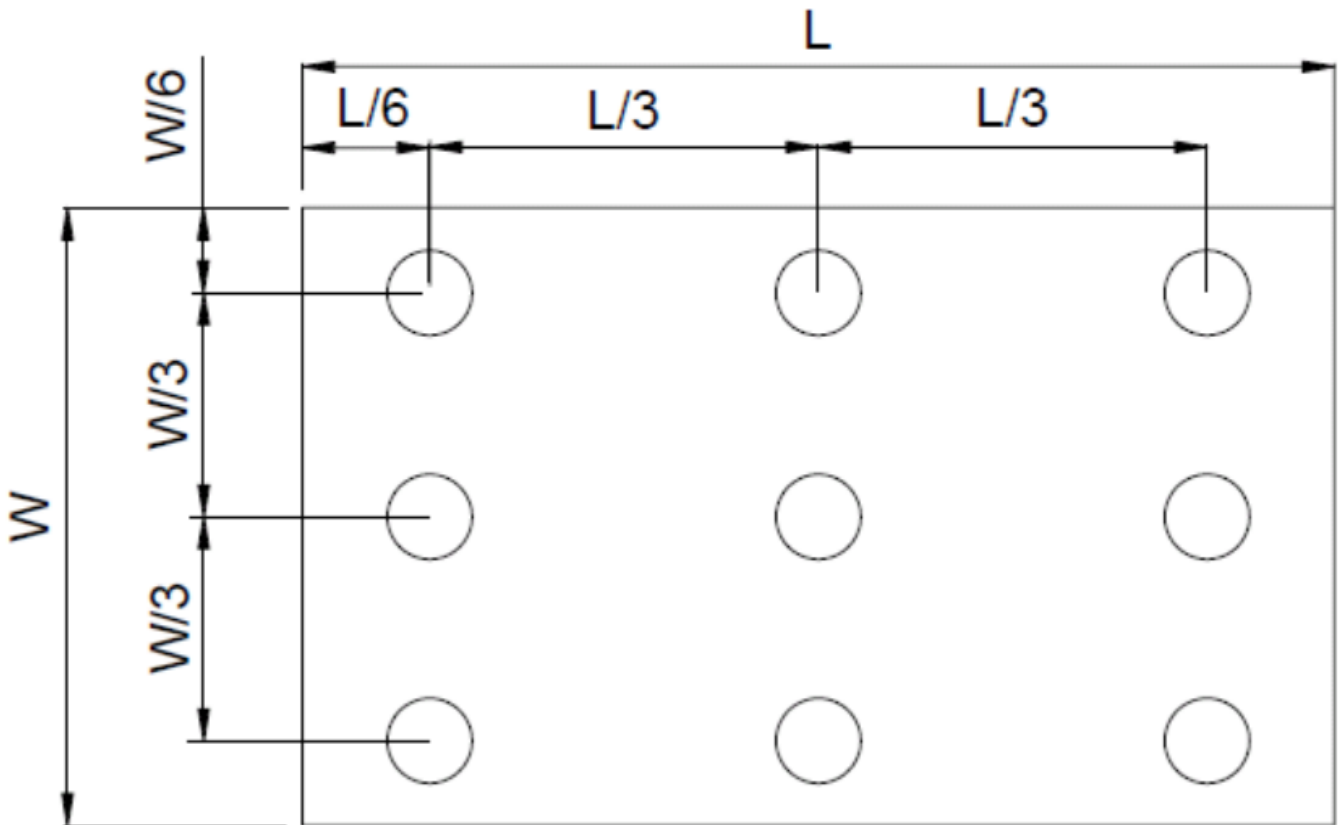

B_{MAX} : The measured maximum luminance of all measurement position.
 B_{MIN} : The measured minimum luminance of all measurement position.



10. Reliability Test Items

10-1. Standard Specifications for Reliability of LCD Module

No	Item	Description
01	High temperature operation	The sample should be allowed to stand at 50°C for 120 hours under driving condition and then returning it to normal temperature condition, and allowing it stand for 2 hours.
02	Low temperature operation	The sample should be allowed to stand at 0°C for 120 hours under driving condition and then returning it to normal temperature condition, and allowing it stand for 2 hours.
03	High temperature storage	The sample should be allowed to stand at 60°C for 120 hours under no-load condition, and then returning it to normal temperature condition and allowing it stand for 2 hours.
04	Low temperature storage	The sample should be allowed to stand at -20°C for 120 hours under no-load condition, then returning it to normal temperature condition, and allowing it stand for 2 hours.
05	Moisture storage	The sample should be allowed to stand at 50°C, 90%RH MAX for 120hours under no-load condition, then taking it out and drying it at normal temperature for 2 hours.
06	Thermal shock storage	The sample should be allowed to stand the following 10 cycles : 0°C for 30 minutes → normal temperature for 5 minutes → +60°C for 30 minutes → normal temperature for 5 minutes, as one cycle.
07	Packing vibration	Frequency range : 10Hz ~ 55Hz Amplitude of vibration : 1.5mm Sweep time: 12 min X, Y, Z 2 hours for each direction.

*Sample size for each test item is 3~5pcs



10 - 2. Testing Conditions and Inspection Criteria

For the final test the testing sample must be stored at room temperature for 24 hours, after the tests listed in Table 10-1, Standard specifications for Reliability have been executed in order to ensure stability.

No	Item	Test Model	In section Criteria
01	Current Consumption	Refer To Specification	The current consumption should conform to the product specification.
02	Contrast	Refer To Specification	After the tests have been executed, the contrast must be larger than half of its initial value prior to the tests.
03	Appearance	Visual inspection	Defect free.

10- 3. MTBF

MTBF	Functions, performance, appearance, etc. shall be free from remarkable deterioration within 50,000 hours under ordinary operating and storage conditions room temperature ($25 \pm 5^{\circ}\text{C}$), normal humidity ($50 \pm 10\%$ RH), and in area not exposed to direct sun light.
------	---



11. Specification of Quality Assurance:

11-1. Purpose

This standard for Quality Assurance should affirm the quality of LCD module products to supply to purchaser by YEEBO CORPORATION (Supplier).

11-2. Standard for Quality Test

a. Inspection:

Before delivering, the supplier should take the following tests, and affirm the quality of product.

b. Electro-Optical Characteristics:

According to the individual specification to test the product.

c. Test of Appearance Characteristics:

According to the individual specification to test the product.

d. Test of Reliability Characteristics:

According to the definition of reliability on the specification for testing products.

e. Delivery Test:

Before delivering, the supplier should take the delivery test.

(i) Test method: According to ISO2859-1. General Inspection Level II take a single time.

(ii) The defects classify of AQL as following:

Major defect: AQL = 0.65%

Minor defect: AQL = 2.5%

Total defects: AQL = 2.5%

11-3. Non- conforming Analysis & Deal With Manners

a. Non- conforming Analysis:

(i) Purchaser should supply the detail data of non- conforming sample and the non- conforming.

(ii) After accepting the detail data from purchaser, the analysis of non- conforming should be finished in two weeks.

(iii) If supplier can not finish analysis on time, must announce purchaser before 3 days.

b. Disposition of non- conforming:

(i) If find any product defect of supplier during assembly time, supplier must change the good product for every defect after recognition.

(ii) Both supplier and customer should analyze the reason and discuss the disposition of non- conforming when the reason of nonconforming is not sure.

11-4. Agreement items

Both sides should discuss together when the following problems happen.

a. There is any problem of standard of quality assurance, and both sides should think that must be modified.

b. There is any argument item which does not record in the standard of quality assurance.

c. Any other special problem.

11-5. Standard of The Product Appearance Test

a. Manner of appearance test:

(i) The test must be under 20W × 2 or 40W fluorescent light, and the distance of view must be at 30±5cm.

(ii) When test the model of transmissive product must add the reflective plate.

(iii) The test direction is base on around 10° of vertical line.

(iii) Temperature: 25±5°C Humidity: 60±10%RH

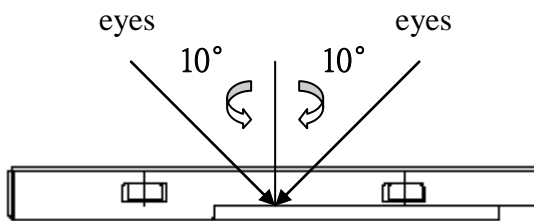

(iv) Definition of area:

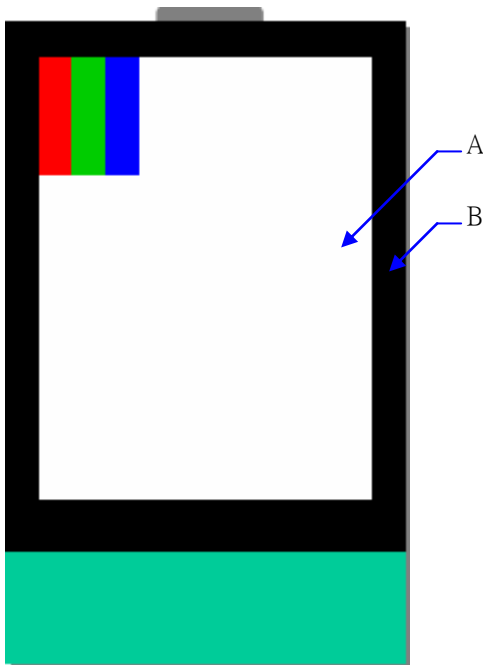

A. Area: Viewing area.

B. Area: Out of viewing area.

(Outside viewing area)

b. Basic principle:

(i) It will accord to the AQL when the standard can not be described.

(ii) The sample of the lowest acceptable quality level must be discussed by both supplier and customer when any dispute happened.

(iii) Must add new item on time when it is necessary.

c. Standard of inspection: (Unit: mm)

11-6. Inspection specification

Defect out of viewing area can be neglected.

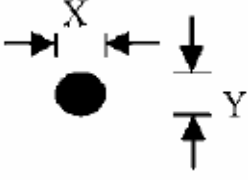
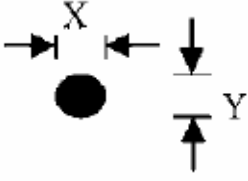
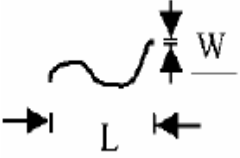
NO	Item	Criterion	AQL										
01	Electrical Testing	1.1 Missing vertical, horizontal segment, segment contrast defect. 1.2 Missing character, dot or icon. 1.3 Display malfunction. 1.4 No function or no display. 1.5 Current consumption exceeds product specifications. 1.6 LCD viewing angle defect. 1.7 Mixed product types. 1.8 Flicker	0.65										
02	Black or White spots or Bright spots or Color spots on LCD (Display only)	2.1 White and black or color spots on display $\leq 0.25\text{mm}$, no more than Five spots. 2.2 Densely spaced: No more than three spots within 3mm. $\Phi = (X+Y) / 2$  <table border="1" data-bbox="829 851 1364 1064"> <thead> <tr> <th>Size(mm)</th> <th>Acceptable Q'ty</th> </tr> </thead> <tbody> <tr> <td>$\Phi \leq 0.20$</td> <td>Accept no dense</td> </tr> <tr> <td>$0.2 < \Phi \leq 0.30$</td> <td>3</td> </tr> <tr> <td>$0.30 < \Phi \leq 0.50$</td> <td>2</td> </tr> <tr> <td>$D > 0.5$</td> <td>0</td> </tr> </tbody> </table>	Size(mm)	Acceptable Q'ty	$\Phi \leq 0.20$	Accept no dense	$0.2 < \Phi \leq 0.30$	3	$0.30 < \Phi \leq 0.50$	2	$D > 0.5$	0	2.5
Size(mm)	Acceptable Q'ty												
$\Phi \leq 0.20$	Accept no dense												
$0.2 < \Phi \leq 0.30$	3												
$0.30 < \Phi \leq 0.50$	2												
$D > 0.5$	0												
03	LCD and Touch Panel black spots, white spots, contamination (non – display)	3.1 Round type: As following drawing $\Phi = (X+Y) / 2$  <table border="1" data-bbox="829 1176 1364 1388"> <thead> <tr> <th>Size(mm)</th> <th>Acceptable Q'ty</th> </tr> </thead> <tbody> <tr> <td>$\Phi \leq 0.15$</td> <td>Accept no dense</td> </tr> <tr> <td>$0.15 < \Phi \leq 0.30$</td> <td>3</td> </tr> <tr> <td>$0.30 < \Phi \leq 0.50$</td> <td>2</td> </tr> <tr> <td>$D > 0.5$</td> <td>0</td> </tr> </tbody> </table> <p style="text-align: center;">* Densely spaced: No more than two spots within 3mm.</p>	Size(mm)	Acceptable Q'ty	$\Phi \leq 0.15$	Accept no dense	$0.15 < \Phi \leq 0.30$	3	$0.30 < \Phi \leq 0.50$	2	$D > 0.5$	0	2.5
		Size(mm)	Acceptable Q'ty										
$\Phi \leq 0.15$	Accept no dense												
$0.15 < \Phi \leq 0.30$	3												
$0.30 < \Phi \leq 0.50$	2												
$D > 0.5$	0												
3.2 Line type: (As following drawing)  <table border="1" data-bbox="694 1579 1364 1769"> <thead> <tr> <th>Length(mm)</th> <th>Width(mm)</th> <th>Acceptable Q'ty</th> </tr> </thead> <tbody> <tr> <td>$L \leq 6$</td> <td>$W \leq 0.05$</td> <td>Accept no dense</td> </tr> <tr> <td>$L \leq 6$</td> <td>$0.05 < W \leq 0.25$</td> <td>2</td> </tr> <tr> <td>$L > 6$</td> <td>$0.25 < W$</td> <td>Rejection</td> </tr> </tbody> </table> <p style="text-align: center;">* Densely spaced: No more than two lines within 3mm.</p>	Length(mm)	Width(mm)	Acceptable Q'ty	$L \leq 6$	$W \leq 0.05$	Accept no dense	$L \leq 6$	$0.05 < W \leq 0.25$	2	$L > 6$	$0.25 < W$	Rejection	
Length(mm)	Width(mm)	Acceptable Q'ty											
$L \leq 6$	$W \leq 0.05$	Accept no dense											
$L \leq 6$	$0.05 < W \leq 0.25$	2											
$L > 6$	$0.25 < W$	Rejection											

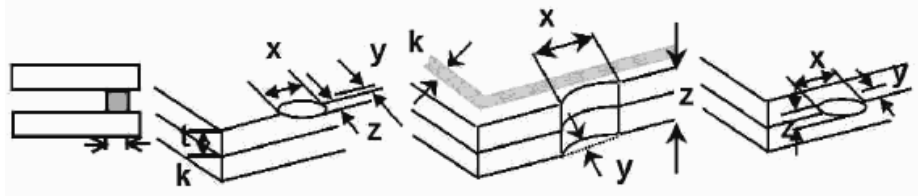
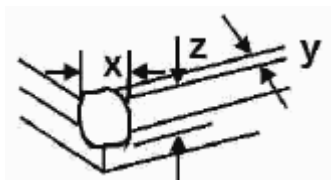
NO	Item	Criterion	AQL																		
04	Polarizer bubbles	<p>If bubbles are visible, judge using black spot specifications, not easy to find, must check in specify direction</p> <table border="1"> <thead> <tr> <th>Size Φ(mm)</th> <th>Acceptable Q'ty</th> </tr> </thead> <tbody> <tr> <td>$\Phi \leq 0.2$</td> <td>Accept no dense</td> </tr> <tr> <td>$0.2 < \Phi \leq 0.30$</td> <td>2</td> </tr> <tr> <td>$0.30 < \Phi \leq 0.50$</td> <td>1</td> </tr> <tr> <td>$0.50 < \Phi \leq 1.0$</td> <td>2</td> </tr> <tr> <td>$1 < \Phi$</td> <td>0</td> </tr> </tbody> </table>	Size Φ (mm)	Acceptable Q'ty	$\Phi \leq 0.2$	Accept no dense	$0.2 < \Phi \leq 0.30$	2	$0.30 < \Phi \leq 0.50$	1	$0.50 < \Phi \leq 1.0$	2	$1 < \Phi$	0	2.5						
Size Φ (mm)	Acceptable Q'ty																				
$\Phi \leq 0.2$	Accept no dense																				
$0.2 < \Phi \leq 0.30$	2																				
$0.30 < \Phi \leq 0.50$	1																				
$0.50 < \Phi \leq 1.0$	2																				
$1 < \Phi$	0																				
05	Scratches	Follow NO.3 -2 Line Type.	2.5																		
06	Chipped glass	<p>Symbols: x: Chip length y: Chip width z: Chip thickness k: Seal width t: Glass thickness a: LCD side length L: Electrode pad length</p> <p>6.1 General glass chip: 6.1.1 Chip on panel surface and crack between panels:</p>  <table border="1"> <thead> <tr> <th>z: Chip thickness</th> <th>y: Chip width</th> <th>x: Chip length</th> </tr> </thead> <tbody> <tr> <td>$Z \leq 1/2t$</td> <td>Not over viewing area</td> <td>$x \leq 1/8a$</td> </tr> <tr> <td>$1/2t < z \leq 2t$</td> <td>Not exceed 1/3k</td> <td>$x \leq 1/8a$</td> </tr> </tbody> </table> <p>⊙ Unit: mm ⊙ If there are 2 or more chips, x is the total length of each chip</p> <p>6.1.2 Corner crack:</p>  <table border="1"> <thead> <tr> <th>z: Chip thickness</th> <th>y: Chip width</th> <th>x: Chip length</th> </tr> </thead> <tbody> <tr> <td>$Z \leq 1/2t$</td> <td>Not over viewing area</td> <td>$x \leq 1/8a$</td> </tr> <tr> <td>$1/2t < z \leq 2t$</td> <td>Not exceed 1/3k</td> <td>$x \leq 1/8a$</td> </tr> </tbody> </table> <p>⊙ Unit: mm ⊙ If there are 2 or more chips, x is the total length of each chip</p>	z: Chip thickness	y: Chip width	x: Chip length	$Z \leq 1/2t$	Not over viewing area	$x \leq 1/8a$	$1/2t < z \leq 2t$	Not exceed 1/3k	$x \leq 1/8a$	z: Chip thickness	y: Chip width	x: Chip length	$Z \leq 1/2t$	Not over viewing area	$x \leq 1/8a$	$1/2t < z \leq 2t$	Not exceed 1/3k	$x \leq 1/8a$	2.5
z: Chip thickness	y: Chip width	x: Chip length																			
$Z \leq 1/2t$	Not over viewing area	$x \leq 1/8a$																			
$1/2t < z \leq 2t$	Not exceed 1/3k	$x \leq 1/8a$																			
z: Chip thickness	y: Chip width	x: Chip length																			
$Z \leq 1/2t$	Not over viewing area	$x \leq 1/8a$																			
$1/2t < z \leq 2t$	Not exceed 1/3k	$x \leq 1/8a$																			

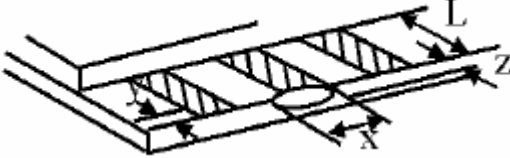
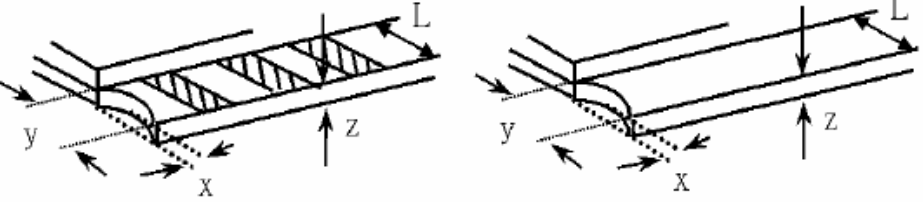
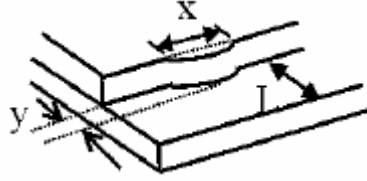
NO	Item	Criterion	AQL																
07	Glass crack	<p>Symbols: x: Chip length y: Chip width z: Chip thickness k: Seal width t: Glass thickness a: LCD side length L: Electrode pad length</p> <p>7.2 Protrusion over terminal: 7.2.1 Chip on electrode pad:</p>  <table border="1" data-bbox="550 683 1220 817"> <tr> <td>y: Chip width</td> <td>x: Chip length</td> <td>z: Chip thickness</td> </tr> <tr> <td>$y \leq 0.5\text{mm}$</td> <td>$x \leq 1/8a$</td> <td>$0 < z \leq t$</td> </tr> </table> <p>7.2.2 Non-conductive portion:</p>  <table border="1" data-bbox="550 1198 1220 1332"> <tr> <td>y: Chip width</td> <td>x: Chip length</td> <td>z: Chip thickness</td> </tr> <tr> <td>$y \leq L$</td> <td>$x \leq 1/8a$</td> <td>$0 < z \leq t$</td> </tr> </table> <p>⊙ If there chipped area touches the ITO terminal, over 2/3 of the ITO must remain and be inspected according to electrode terminal specifications. ⊙ If the product will be heat sealed by the customer, the alignment mark must not be damaged.</p> <p>7.2.3 Substrate protuberance and internal crack</p>  <table border="1" data-bbox="869 1668 1300 1803"> <tr> <td>y: width</td> <td>x: length</td> </tr> <tr> <td>$y \leq 1/3L$</td> <td>$X \leq a$</td> </tr> </table>	y: Chip width	x: Chip length	z: Chip thickness	$y \leq 0.5\text{mm}$	$x \leq 1/8a$	$0 < z \leq t$	y: Chip width	x: Chip length	z: Chip thickness	$y \leq L$	$x \leq 1/8a$	$0 < z \leq t$	y: width	x: length	$y \leq 1/3L$	$X \leq a$	2.5
y: Chip width	x: Chip length	z: Chip thickness																	
$y \leq 0.5\text{mm}$	$x \leq 1/8a$	$0 < z \leq t$																	
y: Chip width	x: Chip length	z: Chip thickness																	
$y \leq L$	$x \leq 1/8a$	$0 < z \leq t$																	
y: width	x: length																		
$y \leq 1/3L$	$X \leq a$																		

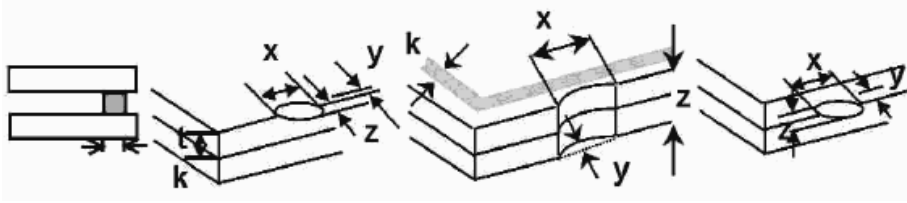
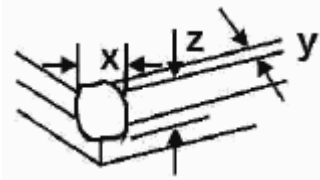

NO	Item	Criterion	AQL
08	Cracked glass	The LCD with extensive crack is not acceptable.	2.5
09	Backlight elements	9.1 Illumination source flickers when lit. 9.2 Spots or scratches that appear when lit must be judged. Using LCD spot, lines and contamination standards. 9.3 Backlight doesn't light or color is wrong.	2.5 2.5 0.65
10	Bezel	Bezel must comply with product specifications.	2.5
11	PCB、COB	11.1 COB seal may not have pinholes larger than 0.2mm or contamination. 11.2 COB seal surface may not have pinholes through to the IC. 11.3 The height of the COB should not exceed the height indicated in the assembly diagram. 11.4 There may not be more than 2mm of sealant outside the seal area on PCB. And there should be no more than three places. 11.5 Parts on PCB must be the same as on the production characteristic chart, There should be no wrong parts, missing parts or excess parts. 11.6 The jumper on the PCB should conform to the product characteristic chart.	2.5 2.5 2.5 2.5 0.65 0.65
12	FPC	12.1 FPC terminal damage \cong 1/2 FPC terminal width and can not affect the function, we judge accept. 12.2 FPC alignment hole damage \cong 1/2 alignment area and can not affect the function, we judge accept.	2.5 2.5
13	Soldering	13.1 No cold solder joints, missing solder connections, oxidation or icicle. 13.2 No short circuits in components on PCB or FPC.	2.5 0.65

NO	Item	Criterion	AQL												
14	Touch Panel Chipped glass	<p>Symbols: x: Chip length y: Chip width z: Chip thickness k: Seal width t: Touch Panel Total thickness a: LCD side length L: Electrode pad length</p> <p>14.1 General glass chip: 14.1.1 Chip on panel surface and crack between panels:</p>  <table border="1" data-bbox="414 795 1236 1019"> <tr> <td>z: Chip thickness</td> <td>y: Chip width</td> <td>x: Chip length</td> </tr> <tr> <td>$Z \leq t$</td> <td>$\leq 1/2 k$ and not over viewing area</td> <td>$x \leq 1/8a$</td> </tr> </table> <p>⊙ Unit: mm ⊙ If there are 2 or more chips, x is the total length of each chip</p> <p>14.1.2 Corner crack:</p>  <table border="1" data-bbox="414 1400 1236 1624"> <tr> <td>z: Chip thickness</td> <td>y: Chip width</td> <td>x: Chip length</td> </tr> <tr> <td>$z \leq t$</td> <td>$\leq 1/2 k$ and not over viewing area</td> <td>$x \leq 1/8a$</td> </tr> </table> <p>⊙ Unit: mm ⊙ If there are 2 or more chips, x is the total length of each chip</p>	z: Chip thickness	y: Chip width	x: Chip length	$Z \leq t$	$\leq 1/2 k$ and not over viewing area	$x \leq 1/8a$	z: Chip thickness	y: Chip width	x: Chip length	$z \leq t$	$\leq 1/2 k$ and not over viewing area	$x \leq 1/8a$	2.5
z: Chip thickness	y: Chip width	x: Chip length													
$Z \leq t$	$\leq 1/2 k$ and not over viewing area	$x \leq 1/8a$													
z: Chip thickness	y: Chip width	x: Chip length													
$z \leq t$	$\leq 1/2 k$ and not over viewing area	$x \leq 1/8a$													

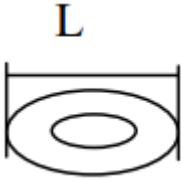
NO	Item	Criterion	AQL						
15	Touch Panel(Fish eye)	<table border="1"> <thead> <tr> <th>SIZE(mm)</th> <th>Acceptable Q'ty</th> </tr> </thead> <tbody> <tr> <td>$L \leq 0.7$</td> <td>Accept no dense</td> </tr> <tr> <td>$0.7 < L$</td> <td>0</td> </tr> </tbody> </table>	SIZE(mm)	Acceptable Q'ty	$L \leq 0.7$	Accept no dense	$0.7 < L$	0	2.5
		SIZE(mm)	Acceptable Q'ty						
$L \leq 0.7$	Accept no dense								
$0.7 < L$	0								
									
16	Touch Panel Newton ring	Newton ring dimension \cong 1/2 touch panel area and not affect font and line distortion (\cong 2.5%), it is acceptable.	2.5						
17	Touch Panel Linearity	Less than 2.5% is acceptable.	2.5						
18	LCD Ripple	Touch the touch panel, can not see the LCD ripple. Pen: R 1.0mm silicon rubber. Operation Force: 80g	2.5						
19	General appearance	19.1 Pin type must match type in specification sheet.	0.65						
		19.2 LCD pin loose or missing pins.	0.65						
		19.3 Product packaging must the same as specified on packaging specification sheet.	0.65						
		19.4 Product dimension and structure must conform to product specification sheet.	0.65						



12. Handling Precaution:

12-1 Handling of LCM

- Don't give external shock.
- Don't apply excessive force on the surface.
- Liquid in LCD is hazardous substance. Must not lick and swallow. when the liquid is attach to your hand, skin, cloth etc. Wash it out thoroughly and immediately.
- Don't operate it above the absolute maximum rating.
- Don't disassemble the LCM.
- The operators should be grounded whenever he/she comes into contact with the module. Never touch any of the conductive parts such as the LSI pads,the copper leads on the PCB and the interface terminals with any parts of the human body.
- The modules should be kept in antistatic bags or other containers resistant to static for storage.
- The module is coated with a film to protect the display surface. Be care when peeling off this protective film since static electricity may be generated.

12-2 Storage

- Store in an ambient temperature of $25 \pm 10^{\circ}\text{C}$, and in a relative humidity of $50 \pm 10\% \text{RH}$, and must be used within six months after delivery from our factory.
Don't expose to sunlight or fluorescent light.
- Storage in a clean environment, free from dust, active gas, and solvent.
- Store in anti-static electricity container.
- Store without any physical load
- Appearance,3months;Function,1year;within the validity, failed CTP can be replaced 1 to 1

12-3 Soldering

- Use only soldering irons with proper grounding and no leakage.
- Iron: No higher than $280 \pm 10^{\circ}\text{C}$ and less than 3 sec during Hand soldering.
- Rewiring: no more than 2 times.

13. Guarantee:

Our products meet requirements of the environment.
YEEBO ROHS requirement is based on European Union Directive 2011/65/EU (ROHS) Requirements and Update.