

7025 Channel style heat sink with folded back fins

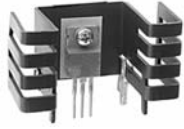

Channel style heat sink with folded back fins for increased cooling surface area. Available with tin plated solderable tabs for easy attachment to the printed circuit card.

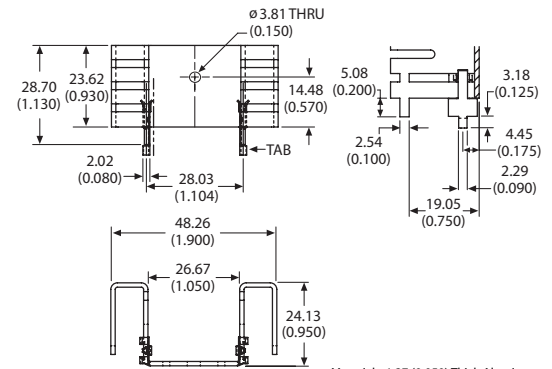
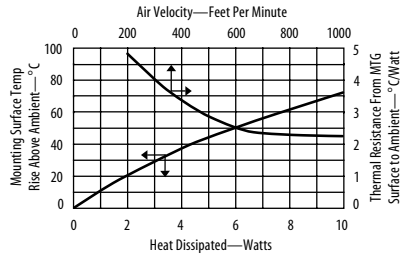

ORDERING INFORMATION

Part Number	Description	Dia of PCB Plated Thru Hole for Tabs
7025BG	Channel heat sink with no solderable tabs	
7025B-MTG	With solderable mounting tabs	2.90 (0.114)

For additional options see page 85

7019 Narrow channel style heat sink with folded back fins

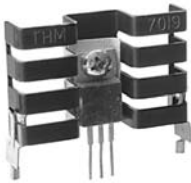

Narrow channel style heat sink with folded back fins for increased cooling surface area. Available with tin plated solderable tabs for easy attachment to the printed circuit card.

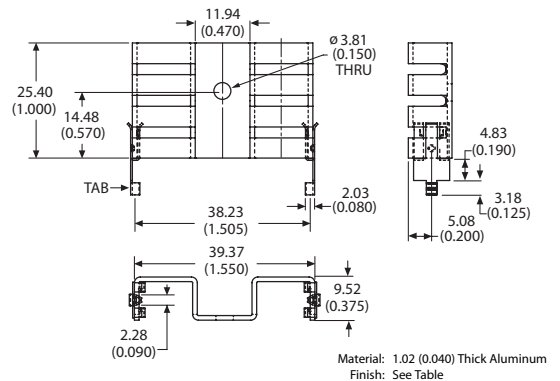
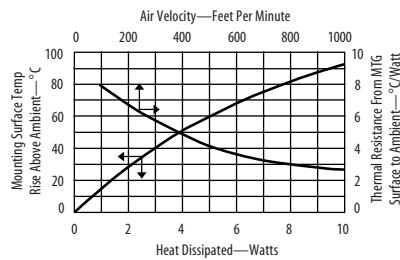

ORDERING INFORMATION

Part Number	Description	Finish	Dia of PCB Plated Thru Hole for Tabs
7019BG	Channel heat sink with no solderable tabs	Black anodize	
7019PBG	Channel heat sink with no solderable tabs	Pre black anodize*	
7019B-MTG	With solderable tabs	Black anodize	2.90 (0.114)

*Edges cut during the manufacturing process will be unfinished. See page 110 for more information

For additional options see page 85

7020 Narrow channel style heat sink with folded back fins



Narrow channel style heat sink with folded back fins for increased cooling surface area. Available with tin plated solderable tabs for easy attachment to the printed circuit card.

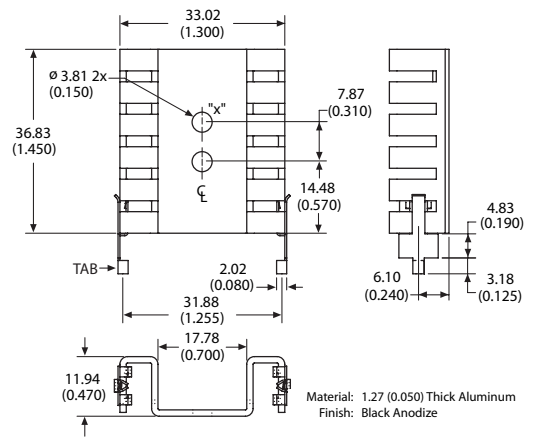
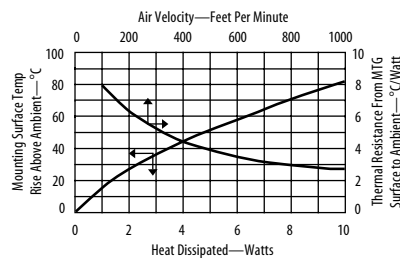

ORDERING INFORMATION

Part Number	Description	Dia of PCB Plated Thru Hole for Tabs
7020BG	Narrow channel heat sink with no solderable tabs	
7020B-MTG	With solderable tabs	2.90 (0.114)

POPULAR OPTIONS: 7020B-___G

Base part no. A

Position	Code	Description	Location	Details
A	TC10-MT	Insulating device mounting clip and solderable tabs	Hole X	Page 93, 98

For additional options see page 85