

UNIT: mm (毫米)

HBAN

红波

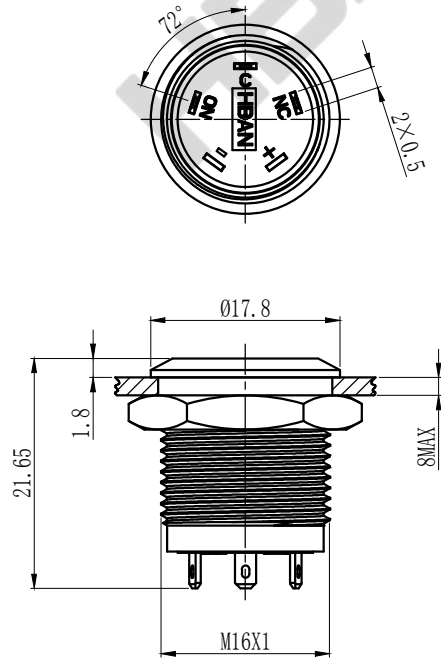

开关结构说明:
Switch structure description:

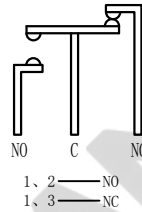

安装孔尺寸:
Mounting hole size:

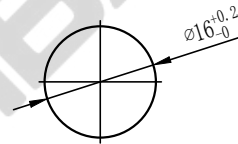

性能要求:

Performance requirements:

- 防护等级: IP67;
Protection grade: IP67.
- 接触电阻: $\leq 100\text{m}\Omega$;
Contact resistance: $\leq 100\text{m}\Omega$.
- 绝缘电阻: $\geq 100\text{M}\Omega$;
The insulation resistance: $\geq 100\text{M}\Omega$.
- 抗电强度: AC250V, 1min, 无闪烁、击穿;
Electrical resistance: AC250V, 1min, no flicker and breakdown;
- 寿命: 电气部分在额定负载下动作1万次无异常。
Life: Electrical part: operate 10,000 times under rated load without any abnormality.
机械部分: 动作5万次无异常;
Mechanical part: no abnormal movement for 50,000times.

技术要求:

Technical requirements:

- 表面光洁, 平整无毛刺;
The surface is smooth without burr;
- 参数/批次字迹清晰, 无错位;
Clear handwriting of parameters/batches without any dislocation;
- 额定电压: $I_{th}: 0.1\text{A}$ $U_i: \text{DC}12\text{V}$;
Rated voltage: 0.1A $U_i: \text{DC}12\text{V}$;
- 工作环境温度: $-25^\circ\text{C} \sim +65^\circ\text{C}$;
Working environment temperature: $-25^\circ\text{C} \sim +65^\circ\text{C}$;
- 动作形式: 自复式; 自锁式;
Operation type: Momentary; Latching;
- 动作行程: 约2.1mm;
Movement stroke: about 2.1mm;
- 连接形式: 焊接导线;
Connection form: welding wire;
- 拧紧力矩: 约0.6Nm;
Tightening torque: about 0.6Nm;
- 开关组合: 1NO1NC;
Contact configuration: 1NO1NC;
- 外观材料: 按键: 不锈钢/PC;
外壳: 不锈钢; 黄铜;
底座: PBT;
触点: 银合金;
Appearance material: Button surface: stainless steel/PC;
Housing: stainless steel; Nickel-Plated Brass
Pedestal: PBT;
Contact silver alloy
- 未标注公差按照GB/T 1804-m级。
Unmarked tolerance shall be in accordance with GB/T 1804-m class.

描 图

描 校

底 图 号

装 订 号

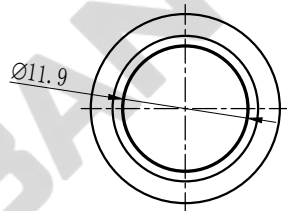

					SHANGHAI HONGBO ELECTRIC CO., LTD.
					上海红波电器有限公司
标记	处数	更改文件号	签字	日期	名称(TITLE): M16 Metal waterproof push button switch
DR. 制图	APPD. 审核	SCALE. 比例	countersign. 会签	Date. 日期	M16金属防水按钮开关
黄	陈秋霞	1.5:1		2022.8.15	图号(DWG NO): HBGQ16F-11(Z)/J/S
PW. 单重		P.		第1页 共1页(1/1)	