

# Ø 175x69 mm

San Ace C175 9TG type

## General Specifications

- Material ..... Motor case: Aluminum (Black coating), Impeller: Plastic (Flammability: UL 94V-0)
- Expected life ..... See the table below. (L10 life: 90% survival rate for continuous operation in free air at 60°C, rated voltage) Expected life at 40°C is for reference only.
- Motor protection function ..... Locked rotor burnout protection, Reverse polarity protection For details, please refer to p. 599.
- Dielectric strength ..... 50/60 Hz, 500 VAC, for 1 minute (between lead wire conductors and motor case)
- Insulation resistance ..... 10 MΩ or more with a 500 VDC megger (between lead wire conductors and motor case)
- Sound pressure level (SPL) ..... At 1 m away from the air inlet
- Storage temperature ..... -30 to +70°C (Non-condensing)
- Lead wire ..... ⊕Red ⊖Black (Sensor) Yellow (Control) Brown
- Mass ..... 750 g

## Specifications When the optional inlet nozzle (109-1073) is mounted.

The models listed below **have pulse sensors with PWM control function.**

Model no.	Rated voltage [V]	Operating voltage range [V]	PWM duty cycle [%]	Rated current [A]	Rated input [W]	Rated speed [min <sup>-1</sup> ]	Max. airflow [m <sup>3</sup> /min] [CFM]	Max. static pressure [Pa] [inchH <sub>2</sub> O]	SPL [dB (A)]	Operating temperature [°C]	Expected life [h]
9TG24P0G01	24	20.4 to 27.6	100	3.9	93.6	4700	14.0 494.7	885 3.55	73	-20 to +60	40000/60°C (70000/40°C)
9TG24P0S01			100	2.35	56.4	3900	11.6 409.8	609 2.45	69		
9TG48P0G01	48	36 to 55.2	100	1.95	93.6	4700	14.0 494.7	885 3.55	73	-20 to +70	

\* PWM input frequency is 25 kHz; models without specifications at 0% PWM duty cycle have zero fan speed at 0%.

Note 1: The maximum rated input value is 130 W.

Note 2: Sensor and control options are available for selection. Refer to the table on p. 636.

## Airflow - Static Pressure Characteristics / PWM Duty - Speed Characteristics Example

**9TG24P0G01** With pulse sensor with PWM control function

PWM duty cycle

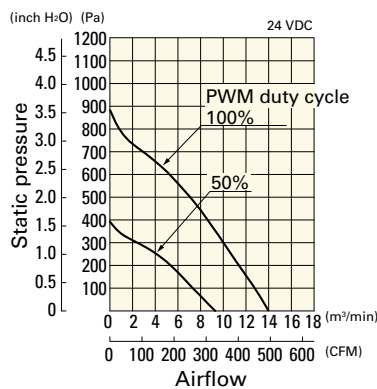

Operating voltage range

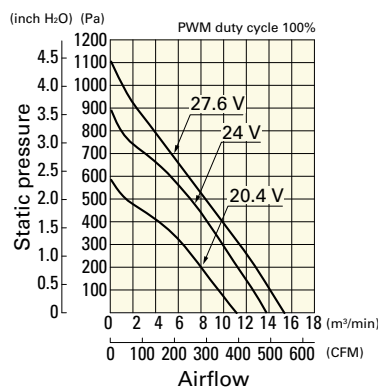

PWM duty - Speed characteristics example

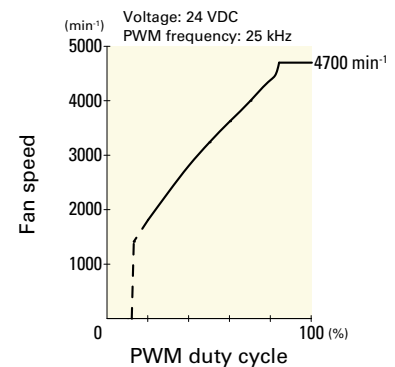

## Airflow - Static Pressure Characteristics / PWM Duty - Speed Characteristics Example

**9TG24P0S01** With pulse sensor with PWM control function

PWM duty cycle

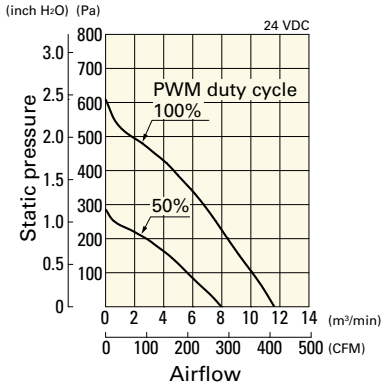

Operating voltage range

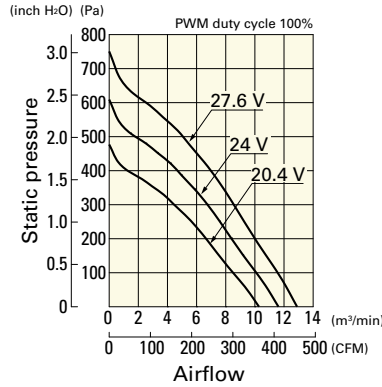

PWM duty - Speed characteristics example

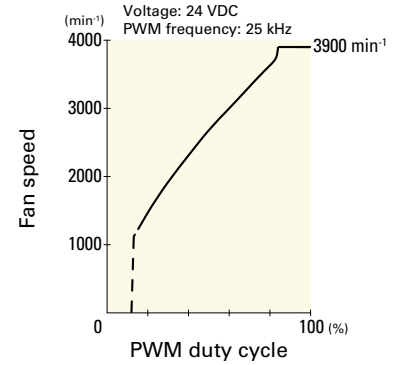

**9TG48P0G01** With pulse sensor with PWM control function

PWM duty cycle

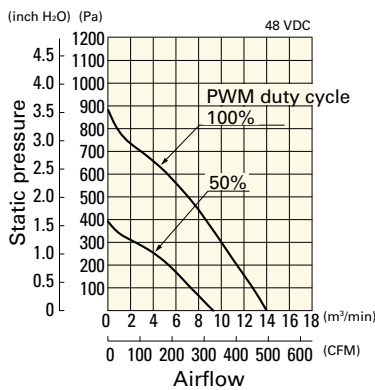

Operating voltage range

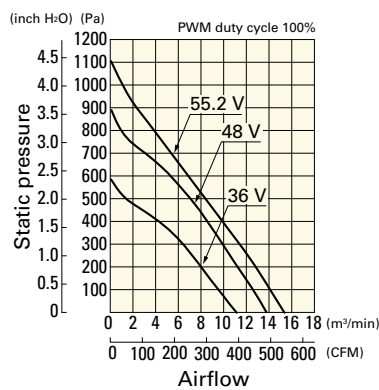

PWM duty - Speed characteristics example

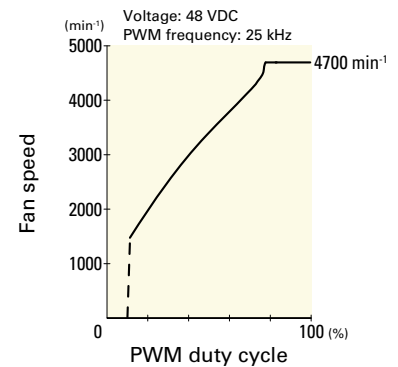

## Dimensions (unit: mm)

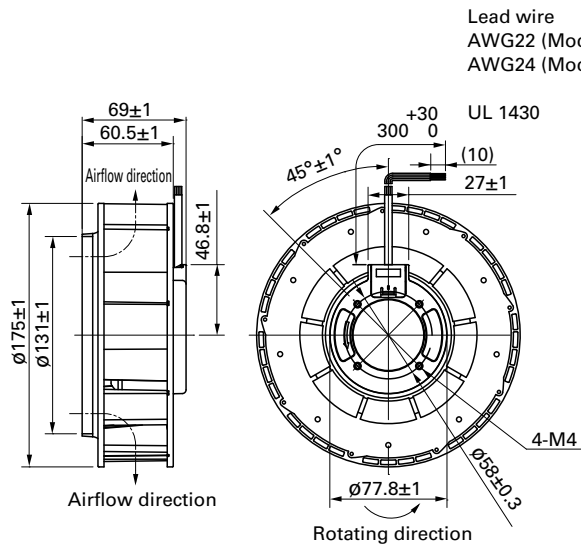

DC  
Centrifugal Fan φ175 mm

## Reference Dimensions of Mounting Holes and Vent Opening (unit: mm)

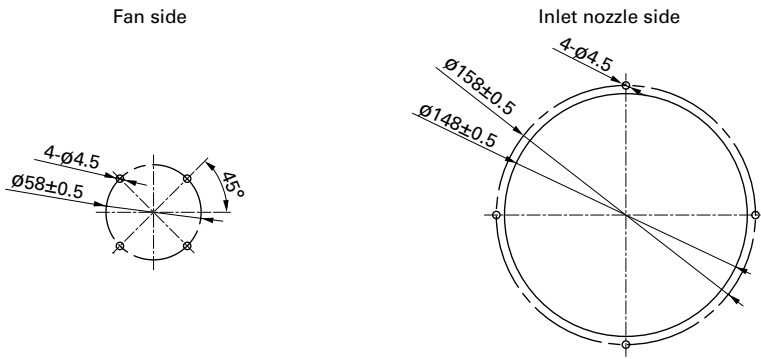

## Reference Diagram for Mounting

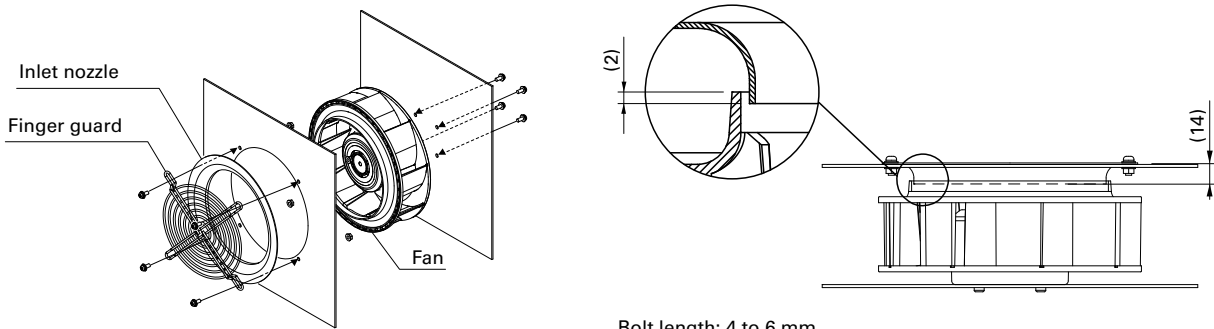

Bolt length: 4 to 6 mm.  
To prevent bolts from loosening, use plain washers and spring washers.

## Options

Finger guards

page: p. 585

Model no.: 109-722, 109-722H

Inlet nozzle

page: p. 589

Model no.: 109-1073, 109-1073H