

TGS 2660 - Ventilation Index Sensor

Features:

- * Long life and low cost
- * Designed to detect air contaminants caused by room occupants
- * Long life and low cost
- * Uses simple electrical circuit

Applications:

- * Control of ventilation fan, kitchen range hood, and air conditioner
- * Air quality monitors
- * Ventilation index monitors*¹

The sensing element is comprised of a metal oxide semiconductor layer formed on an alumina substrate of a sensing chip together with an integrated heater. In the presence of a detectable gas, the sensor's conductivity increases depending on the gas concentration in the air. A simple electrical circuit can convert the change in conductivity to an output signal which corresponds to indoor air pollution level.

There is a high correlation between the sensor output and the air contaminants level affected by occupants in a room. Therefore, TGS2660 is useful for ventilation control and ventilation index monitors. With its compact size, this sensor is the ideal choice for size-oriented applications such as ventilation fans in offices and living areas, and kitchen range hoods.

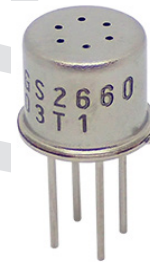

Air Monitoring Data:

The figure below represents the example data of indoor air monitoring by TGS2660 and a NDIR CO₂ sensor (CDM7160) simultaneously.

The Y-axis is indicated as output signal change and the ventilation index level that is calculated from the signal of TGS2660, and concentration indication of CO₂ sensor.

*Room size: 28m³

*Temperature setting for air conditioner: 25°C

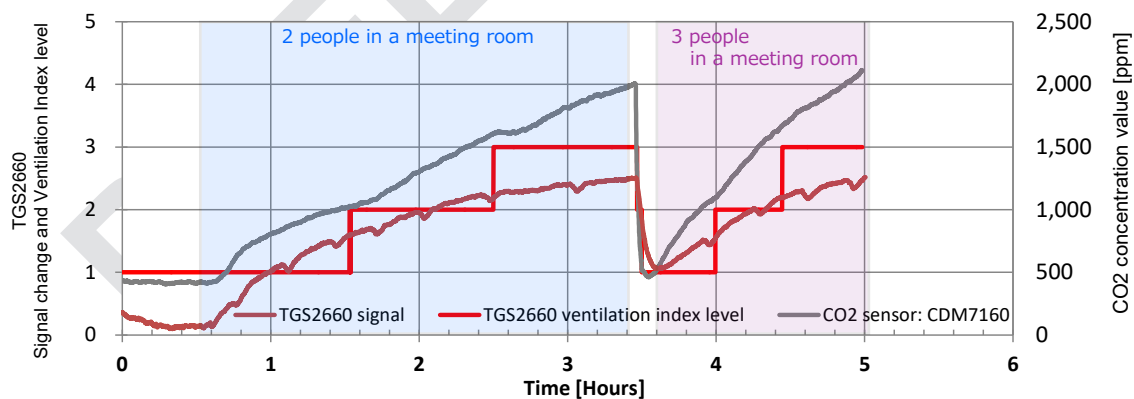

*¹ Evaluation module (EM2660) which is optimized for ventilation index monitor application will be also available soon.

IMPORTANT NOTE: OPERATING CONDITIONS IN WHICH FIGARO SENSORS ARE USED WILL VARY WITH EACH CUSTOMER'S SPECIFIC APPLICATIONS. FIGARO STRONGLY RECOMMENDS CONSULTING OUR TECHNICAL STAFF BEFORE DEPLOYING FIGARO SENSORS IN YOUR APPLICATION AND, IN PARTICULAR, WHEN CUSTOMER'S TARGET GASES ARE NOT LISTED HEREIN. FIGARO CANNOT ASSUME ANY RESPONSIBILITY FOR ANY USE OF ITS SENSORS IN A PRODUCT OR APPLICATION FOR WHICH SENSOR HAS NOT BEEN SPECIFICALLY TESTED BY FIGARO.

Basic Measuring Circuit:

The sensor requires two voltage inputs: heater voltage (V_H) and circuit voltage (V_C). The heater voltage (V_H) is applied to the integrated heater in order to maintain the sensing element at a specific temperature which is optimal for sensing. Circuit voltage (V_C) is applied to allow measurement of voltage (V_{OUT}) across a load resistor (R_L) which is connected in series with the sensor. DC voltage is required for the circuit

since the sensor has a polarity. A common power supply circuit can be used for both V_C and V_H to fulfill the sensor's electrical requirements. The value of the load resistor (R_L) should be chosen to optimize the alarm threshold value, keeping power consumption (P_S) of the semiconductor below a limit of 15mW. Power consumption (P_S) will be highest when the value of R_S is equal to R_L on exposure to gas.

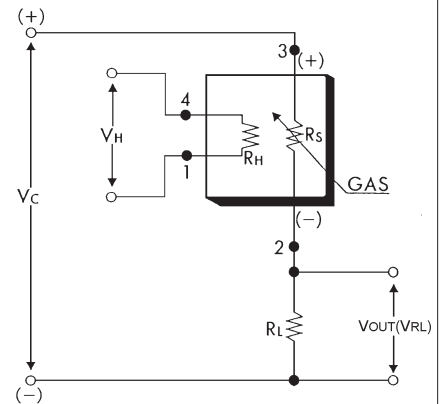

Specifications:

Model number		TGS2660-B00	
Sensing principle		MOS type	
Standard package		TO-5 metal can	
Standard circuit conditions	Heater voltage	V_H	5.0±0.2V DC
	Circuit voltage	V_C	5.0±0.2V DC
	Load resistance	R_L	variable 0.45kΩ min.
Electrical characteristics under standard test conditions	Heater resistance	R_H	approx 83Ω at room temp. (typical)
	Heater current	I_H	42±4mA
	Heater power consumption	P_H	210mW $V_H = 5.0V$ DC
	Sensor resistance	R_S	4kΩ ~ 90kΩ in air
Standard test conditions	Test gas conditions	normal air at 20±2°C, 65±5%RH	
	Circuit conditions	$V_C = 5.0±0.01V$ DC $V_H = 5.0±0.05V$ DC	
	Preheating period before test	1 day or longer	

The value of power consumption (P_S) can be calculated by utilizing the following formula:

$$P_S = \frac{(V_C - V_{RL})^2}{R_S}$$

Sensor resistance (R_S) is calculated with a measured value of $V_{OUT}(V_{RL})$ by using the following formula:

$$R_S = \left(\frac{V_C}{V_{RL}} - 1 \right) \times R_L$$

Structure and Dimensions:

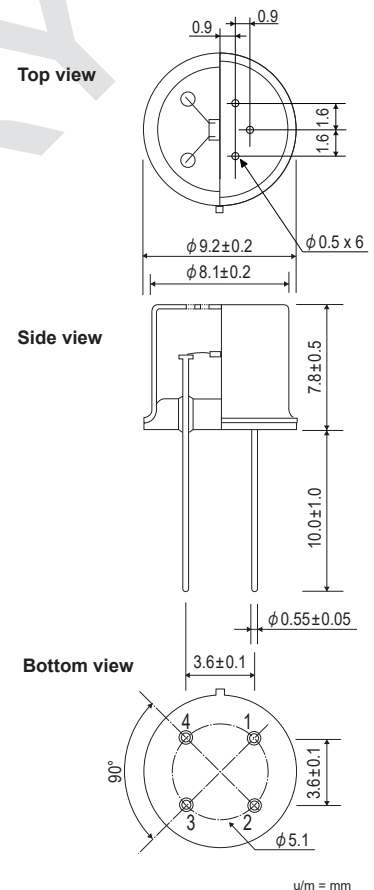

Pin connection:

- 1: Heater
- 2: Sensor electrode (-)
- 3: Sensor electrode (+)
- 4: Heater

NOTE:

The TGS2660 sensor responds to indoor air pollution other than CO₂ that may be caused by room occupants. The sensor does not measure carbon dioxide concentrations.

All sensor characteristics shown in this brochure represent typical characteristics. Actual characteristics vary from sensor to sensor. The only characteristics warranted are those in the Specification table above.

FIGARO ENGINEERING INC.
1-5-11 Senba-nishi
Mino, Osaka 562-8505 JAPAN
Phone: (81)-727-28-2045
URL: www.figaro.co.jp/en/