

## FEATURES

- Wide Operating Voltage Range of 2 V to 6 V
- Outputs Can Drive Up To 10 LSTTL Loads
- Low Power Consumption, 80- $\mu$ A Max  $I_{CC}$
- Typical  $t_{pd} = 13$  ns
- $\pm 4$ -mA Output Drive at 5 V
- Low Input Current of 1  $\mu$ A Max
- Complementary Outputs
- Direct Overriding Load (Data) Inputs
- Gated Clock Inputs
- Parallel-to-Serial Data Conversion

**XL74HC165  
(TOP VIEW)**

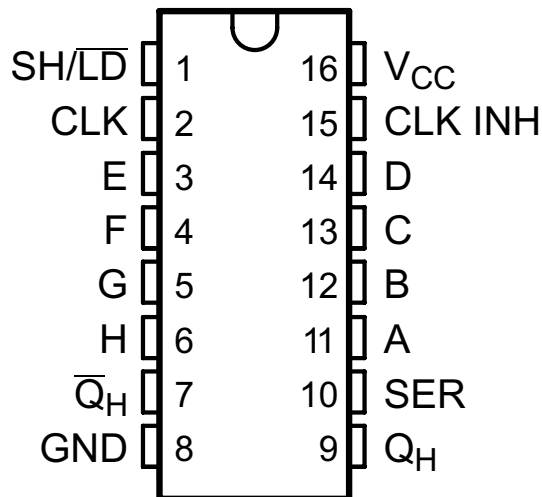

## DESCRIPTION

The 74HC165 devices are 8-bit parallel-load shift registers that, when clocked, shift the data toward a serial ( $Q_H$ ) output. Parallel-in access to each stage is provided by eight individual direct data (A-H) inputs that are enabled by a low level at the shift/load (SH/LD) input. The 'HC165 devices also feature a clock-inhibit (CLK INH) function and a complementary serial ( $\overline{Q}_H$ ) output.

Clocking is accomplished by a low-to-high transition of the clock (CLK) input while SH/LD is held high and CLK INH is held low. The functions of CLK and CLK INH are interchangeable. Since a low CLK and a low-to-high transition of CLK INH also accomplish clocking, CLK INH should be changed to the high level only while CLK is high. Parallel loading is inhibited when SH/LD is held high. While SH/LD is low, the parallel inputs to the register are enabled independently of the levels of the CLK, CLK INH, or serial (SER) inputs.

**FUNCTION TABLE**

SH/LD	INPUTS		FUNCTION
	CLK	CLK INH	
L	X	X	Parallel load
H	H	X	No change
H	X	H	No change
H	L	↑	Shift <sup>(1)</sup>
H	↑	L	Shift <sup>(1)</sup>

- (1) Shift = content of each internal register shifts toward serial output  $Q_H$ . Data at SER is shifted into the first register.

# XL74HC165 SOP16

LOGIC DIAGRAM (POSITIVE LOGIC)

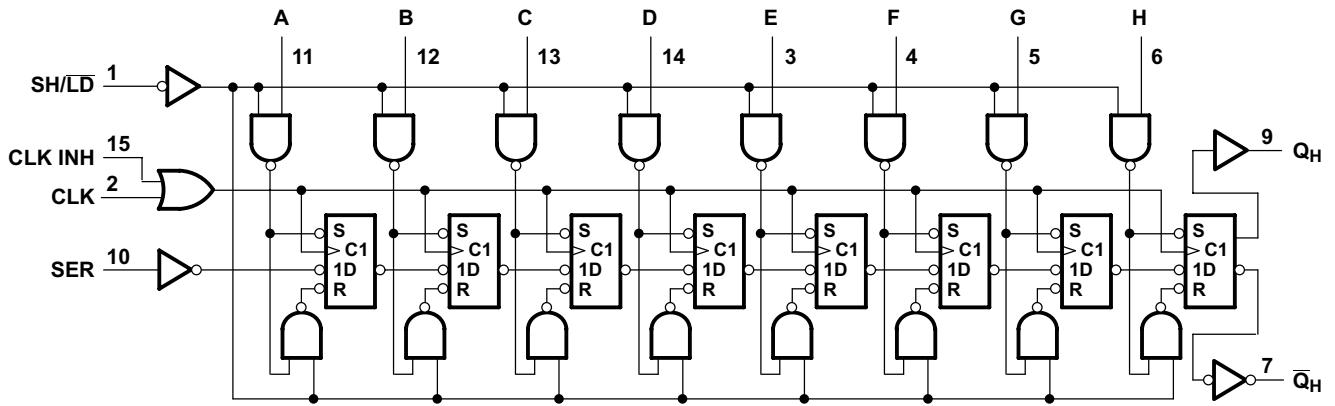

TYPICAL SHIFT, LOAD, AND INHIBIT SEQUENCE

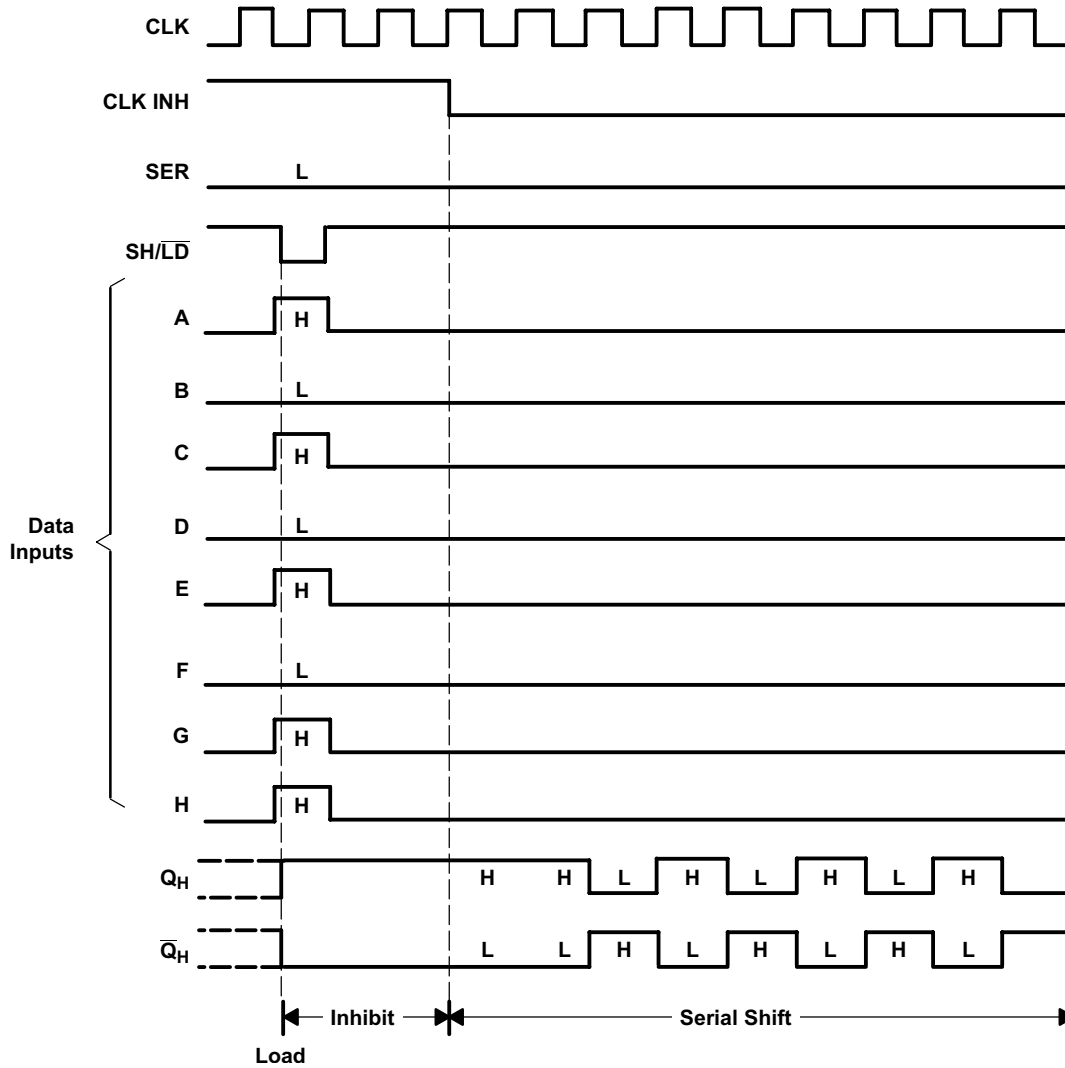

# XL74HC165 SOP16

## ABSOLUTE MAXIMUM RATINGS

over operating free-air temperature range (unless otherwise noted)<sup>(1)</sup>

		VALUE	UNITS
V <sub>CC</sub>	Supply voltage range	-0.5 to 7	V
I <sub>IK</sub>	Input clamp current	V <sub>I</sub> < 0 or V <sub>I</sub> > V <sub>CC</sub> <sup>(2)</sup>	±20 mA
I <sub>OK</sub>	Output clamp current	V <sub>O</sub> < 0 or V <sub>O</sub> > V <sub>CC</sub> <sup>(2)</sup>	±20 mA
I <sub>O</sub>	Continuous output current	V <sub>O</sub> = 0 to V <sub>CC</sub>	±25 mA
Continuous current through V <sub>CC</sub> or GND		±50	mA
θ <sub>JA</sub> <sup>(3)</sup>	Package thermal impedance	D package	73 °C/W
		DB Package	82 °C/W
		N package	67 °C/W
		NS package	64 °C/W
		PW package	108 °C/W
T <sub>stg</sub>	Storage temperature range	-65 to 150	°C

- (1) Stresses beyond those listed under “absolute maximum ratings” may cause permanent damage to the device. These are stress ratings only, and functional operation of the device at these or any other conditions beyond those indicated under “recommended operating conditions” is not implied. Exposure to absolute-maximum-rated conditions for extended periods may affect device reliability.
- (2) The input and output voltage ratings may be exceeded if the input and output current ratings are observed.
- (3) The package thermal impedance is calculated in accordance with JESD 51-7.

## RECOMMENDED OPERATING CONDITIONS<sup>(1)</sup>

over operating free-air temperature range (unless otherwise noted)

		XL74HC165			UNIT
		MIN	NOM	MAX	
V <sub>CC</sub>	Supply voltage	2	5	6	V
V <sub>IH</sub>	High-level input voltage	V <sub>CC</sub> = 2 V	1.5		V
		V <sub>CC</sub> = 4.5 V	3.15		
		V <sub>CC</sub> = 6 V	4.2		
V <sub>IL</sub>	Low level input voltage	V <sub>CC</sub> = 2 V	0.5		V
		V <sub>CC</sub> = 4.5 V	1.35		
		V <sub>CC</sub> = 6 V	1.8		
V <sub>I</sub>	Input voltage	0	V <sub>CC</sub>		V
V <sub>O</sub>	Output voltage	0	V <sub>CC</sub>		V
Δt/Δv <sup>(2)</sup>	Input transition rise/fall time	V <sub>CC</sub> = 2 V	1000		ns
		V <sub>CC</sub> = 4.5 V	500		
		V <sub>CC</sub> = 6 V	400		
T <sub>A</sub>	Operating free-air temperature	-40	125		°C

- (1) All unused inputs of the device must be held at V<sub>CC</sub> or GND to ensure proper device operation. Refer to the TI application report, *Implications of Slow or Floating CMOS Inputs*, literature number SCBA004.
- (2) If this device is used in the threshold region (from V<sub>IL max</sub> = 0.5 V to V<sub>IH min</sub> = 1.5 V), there is a potential to go into the wrong state from induced grounding, causing double clocking. Operating with the inputs at t<sub>r</sub> = 1000 ns and V<sub>CC</sub> = 2 V does not damage the device; however, functionally, the CLK inputs are not ensured while in the shift, count, or toggle operating modes.

# XL74HC165 SOP16

## ELECTRICAL CHARACTERISTICS

over recommended operating free-air temperature range (unless otherwise noted)

PARAMETER	TEST CONDITIONS		V <sub>CC</sub>	T <sub>A</sub> = 25°C			XL74HC165 -40°C TO 85°C		Recommended XL74HC165 -40°C TO 125°C		UNIT
				MIN	TYP	MAX	MIN	MAX	MIN	MAX	
V <sub>OH</sub>	V <sub>I</sub> = V <sub>IH</sub> or V <sub>IL</sub>	I <sub>OH</sub> = -20 μA	2 V	1.9	1.998		1.9		1.9	V	
			4.5 V	4.4	4.499		4.4		4.4		
			6 V	5.9	5.999		5.9		5.9		
		I <sub>OH</sub> = -4 mA	4.5 V	3.98	4.3		3.84		3.7		
			6 V	5.48	5.8		5.34		5.2		
V <sub>OL</sub>	V <sub>I</sub> = V <sub>IH</sub> or V <sub>IL</sub>	I <sub>OL</sub> = 20 μA	2 V		0.002	0.1		0.1		V	
			4.5 V		0.001	0.1		0.1			0.1
			6 V		0.001	0.1		0.1			0.1
		I <sub>OL</sub> = 4 mA	4.5 V		0.17	0.26		0.33			0.4
			6 V		0.15	0.26		0.33			0.4
I <sub>I</sub>	V <sub>I</sub> = V <sub>CC</sub> or 0		6 V		±0.1	±100		±1000		±1000	nA
I <sub>CC</sub>	V <sub>I</sub> = V <sub>CC</sub> or 0, I <sub>O</sub> = 0		6 V			8		80		160	μA
C <sub>i</sub>			2 V to 6 V		3	10		10		10	pF

# XL74HC165 SOP16

## TIMING REQUIREMENTS

over recommended operating free-air temperature range (unless otherwise noted)

			V <sub>CC</sub>	T <sub>A</sub> = 25°C		XL74HC165 -40°C TO 85°C		Recommended XL74HC165 -40°C TO 125°C		UNIT			
				MIN	MAX	MIN	MAX	MIN	MAX				
f <sub>clock</sub>	Clock frequency		2 V	6		5		4.2		MHz			
			4.5 V	31		25		21					
			6 V	36		29		25					
t <sub>w</sub>	Pulse duration	SH/ $\overline{\text{LD}}$ low	2 V	80		100		120		ns			
			4.5 V	16		20		24					
			6 V	14		17		20					
		CLK high or low	2 V	80		100		120					
			4.5 V	16		20		24					
			6 V	14		17		20					
t <sub>su</sub>	Setup time	SH/ $\overline{\text{LD}}$ high before CLK $\uparrow$	2 V	80		100		120		ns			
			4.5 V	16		20		24					
			6 V	14		17		20					
		SER before CLK $\uparrow$	2 V	40		50		60					
			4.5 V	8		10		12					
			6 V	7		9		10					
		CLK INH low before CLK $\uparrow$	2 V	100		125		150					
			4.5 V	20		25		30					
			6 V	17		21		25					
		CLK INH high before CLK $\uparrow$	2 V	40		50		60					
			4.5 V	8		10		12					
			6 V	7		9		10					
		Data before SH/ $\overline{\text{LD}}$ $\downarrow$	2 V	100		125		150					
			4.5 V	20		25		30					
			6 V	17		21		26					
		t <sub>h</sub>	Hold time	SER data after CLK $\uparrow$	2 V	5		5			5		ns
					4.5 V	5		5			5		
					6 V	5		5			5		
PAR data after SH/ $\overline{\text{LD}}$ $\downarrow$	2 V			5		5		5					
	4.5 V			5		5		5					
	6 V			5		5		5					

# XL74HC165 SOP16

## SWITCHING CHARACTERISTICS

over recommended operating free-air temperature range,  $C_L = 50$  pF (unless otherwise noted)

PARAMETER	FROM (INPUT)	TO (OUTPUT)	$V_{CC}$	$T_A = 25^\circ\text{C}$			XL74HC165 -40°C TO 85°C		Recommended XL74HC165 -40°C TO 125°C		UNIT
				MIN	TYP	MAX	MIN	MAX	MIN	MAX	
$f_{max}$			2 V	6	13		5		4.2	MHz	
			4.5 V	31	50		25		21		
			6 V	36	62		29		25		
$t_{pd}$	SH/ $\overline{\text{LD}}$	$Q_H$ or $\overline{Q}_H$	2 V		80	150		190		225	ns
			4.5 V		20	30		38		45	
			6 V		16	26		32		38	
	CLK	$Q_H$ or $\overline{Q}_H$	2 V		75	150		190		225	
			4.5 V		15	30		38		45	
			6 V		13	26		32		38	
	H	$Q_H$ or $\overline{Q}_H$	2 V		75	150		190		225	
			4.5 V		15	30		38		45	
			6 V		13	26		32		38	
$t_t$		Any	2 V		38	75		95		110	ns
			4.5 V		8	15		19		22	
			6 V		6	13		16		19	

## OPERATING CHARACTERISTICS

$T_A = 25^\circ\text{C}$

PARAMETER	TEST CONDITIONS	TYP	UNIT
$C_{pd}$ Power dissipation capacitance	No load	75	pF

# XL74HC165 SOP16

## PARAMETER MEASUREMENT INFORMATION

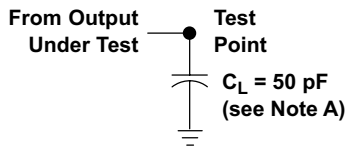

LOAD CIRCUIT

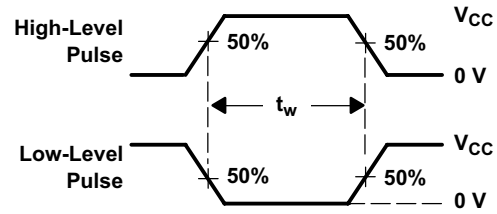

VOLTAGE WAVEFORMS  
PULSE DURATIONS

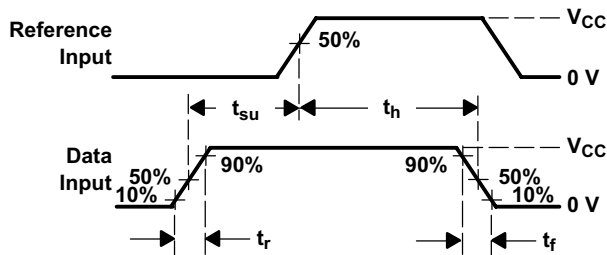

VOLTAGE WAVEFORMS  
SETUP AND HOLD AND INPUT RISE AND FALL TIMES

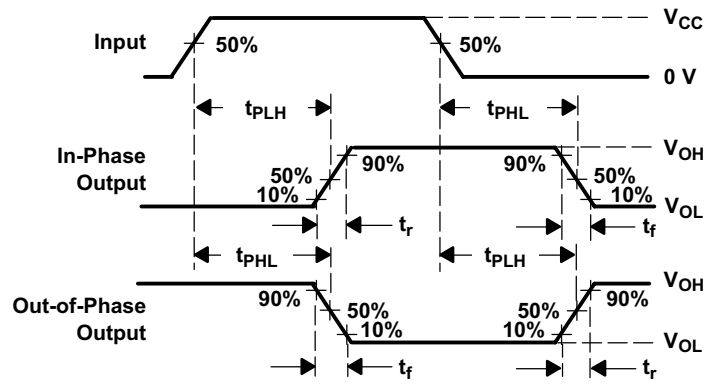

VOLTAGE WAVEFORMS  
PROPAGATION DELAY AND OUTPUT TRANSITION TIMES

- NOTES:
- A.  $C_L$  includes probe and test-fixture capacitance.
  - B. Phase relationships between waveforms were chosen arbitrarily. All input pulses are supplied by generators having the following characteristics:  $PRR \leq 1 \text{ MHz}$ ,  $Z_O = 50 \Omega$ ,  $t_r = 6 \text{ ns}$ ,  $t_f = 6 \text{ ns}$ .
  - C. For clock inputs,  $f_{max}$  is measured when the input duty cycle is 50%.
  - D. The outputs are measured one at a time with one input transition per measurement.
  - E.  $t_{PLH}$  and  $t_{PHL}$  are the same as  $t_{pd}$ .

Figure 1. Load Circuit and Voltage Waveforms

# XL74HC165 SOP16

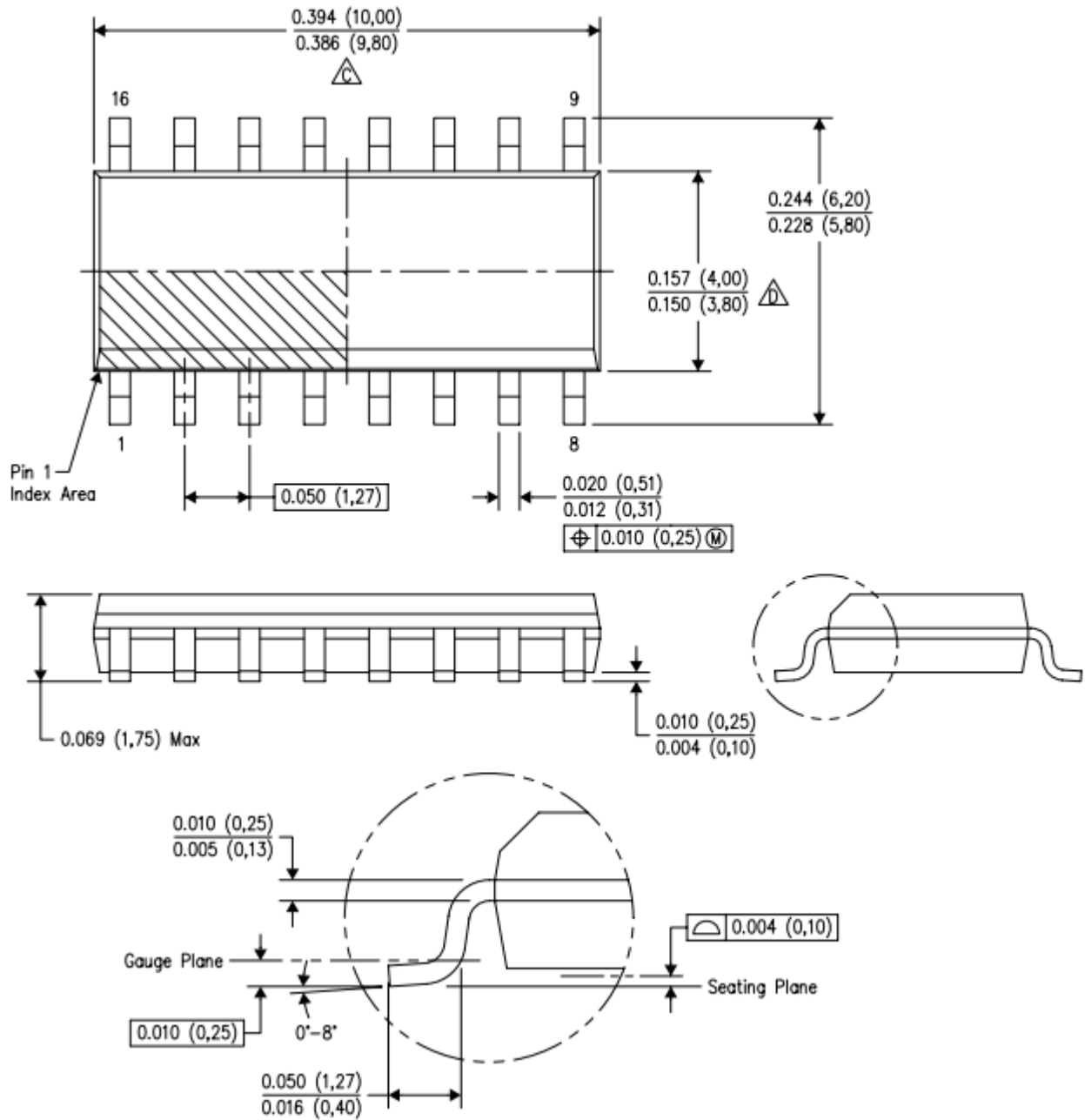

以上信息仅供参考. 如需帮助联系客服人员. 谢谢 XINLUDA