

| SPECIFICATION | VALUE |
|---------------------|------------------------------|
| POWER (Kw) | 2.2 |
| VOLTAGE (VAC) | 110 |
| RATED CURRENT (A) | 12 |
| MAXIMUM SPEED (RPM) | 24000 |
| FREQUENCY (Hz) | 400 |
| NUT MODEL | ER20 |
| COLLET (mm) | Ø6, Ø6.35 |
| RUNOUT OFF (mm) | LESS THAN 0.005 |
| BEARINGS | 2x7005C(P4 DT) + 1x7002C(P4) |
| COOLING | WATER COOLED |
| MATERIAL | STAINLESS STEEL |
| LUBRICATION | GREASE |
| WEIGHT (Kg) [lb] | 5.25 [11.57] |

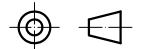
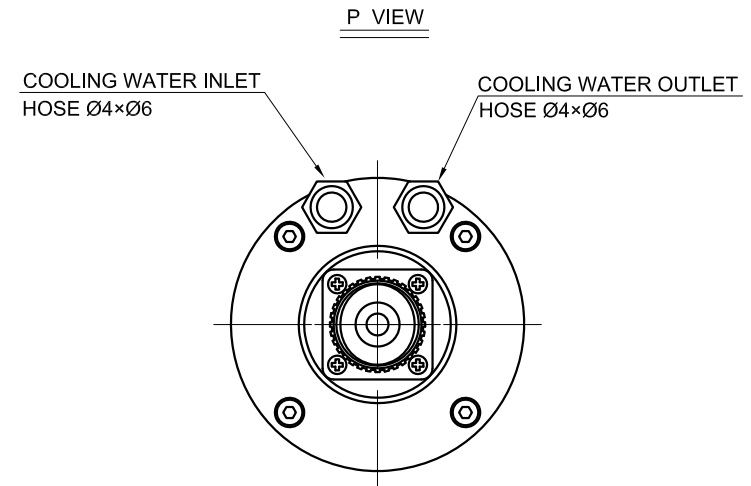

| | | | | | |
|--|-------|-----------|--|----------|------------------------|
| | mm | APVD | | 5.5.2019 | <h2>SPINDLE MOTOR</h2> |
| | UNIT | CHKD | | | |
| | 2:1 | DRN | | | <h3>GDZ80-2.2A</h3> |
| | SCALE | SIGNATURE | | DATE | |