

WD300 WIND DIRECTION SENSOR

MAIN FEATURES

- The sensor has the advantages of compact design, high measurement accuracy, fast response speed and good interchangeability.
- Realize low cost, low price and high performance.
- Flange installation mode can realize lower outgoing line and side outgoing line, which is simple and convenient.
- Reliable performance, ensure normal operation and high data transmission efficiency.
- The power supply has a wide range of adaptability, good linearity of data information and long signal transmission distance.



OVERVIEW

WD300 wind direction sensor is used to measure the direction value of wind and convert it into electrical signal, which can be directly transmitted to the recording equipment for processing.

The sensor shell is made of aluminum, with very small dimensional tolerance, high surface accuracy, high weather resistance, high strength, corrosion resistance and water resistance; the internal circuit has been protected, and the whole sensor has good adaptability to harsh environment. The cable connector is a military plug, which has good anti-corrosion and anti-corrosion performance, can ensure the long-term use of the instrument, and cooperate with the internal imported bearing system to ensure the accuracy of wind direction collection.

The wind direction sensor adopts low inertia wind indicator and precision potentiometer, with high sensitivity and precision. The precise signal processing unit can output various signals according to the user's requirements. The PCB of the circuit module is made of military grade a material, which ensures the stability of parameters and the quality of electrical performance; the electronic components are made of imported industrial grade chips, which makes the whole circuit have a very reliable anti electromagnetic interference ability, and can ensure the normal operation of the host within the range of - 30 °C ~ + 50 °C, humidity 35% ~ 85% (non condensing).

SPECIFICATION

Measurement range	0-360 °
Accuracy	± 1 °
Resolution	0.1 °
Starting wind speed	≤ 0.5m/s
Maximum turning radius	200mm
Output signal	A: Voltage signal (0-2v, 0-5V, 0-10V) B: 4-20mA (current loop) C: RS485 (standard Modbus RTU protocol, device default address: 01)
Supply voltage	5-24vdc (when the output signal is 0-2v, RS485) 12-24vdc (when the output signal is 0-5V, 0-10V, 4-20mA)
Working environment	temperature - 40 °C ~ 70 °C;
Humidity	≤ 100% RH
Protection grade	IP65
Material	aluminum or plastic

DIMENSION

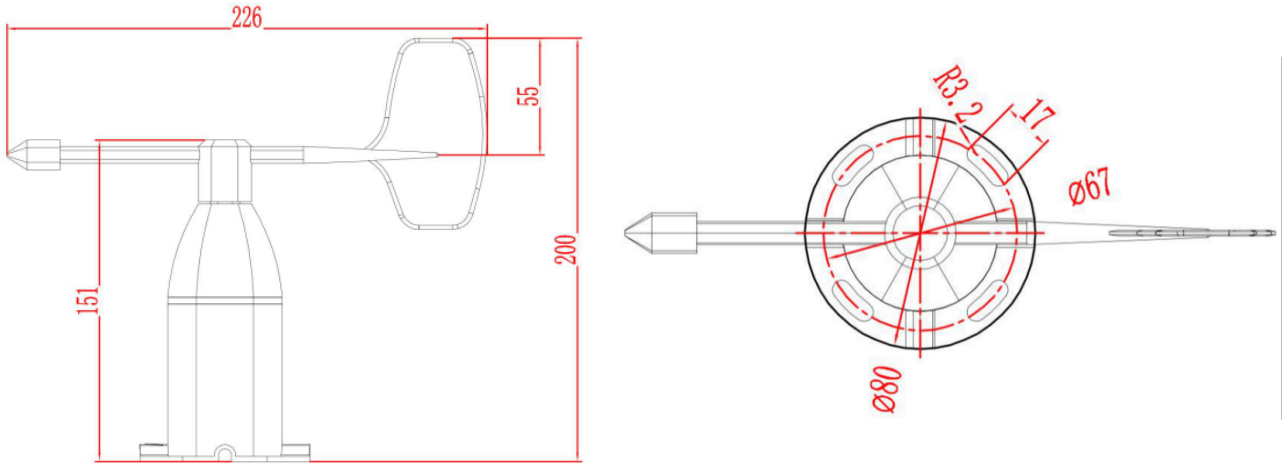

ORDER CODE

WD300	Wind direction Sensor		
	CODE	Material	
	A	aluminum	
	B	PP	
		CODE	Signal output
		1	4~20mA
		2	0-10V
		3	0-5V
		4	RS485
WD300	A	1	Order example

APPLICATION

