

# THM LOW PROFILE LITHIUM-ION & ALKALINE CELL HOLDERS

"1/3N" · "AAA" · "1/2AA" · "CR2" · "AA" · "2/3A"

## FEATURES

- Snap-In PC contact holds firmly in position for wave soldering
- Tin Nickel contacts for excellent solderability and durability
- Polarity clearly marked for orientation
- Snap-on retainer cover (optional) retains battery securely to withstand shock and vibration. Helps protect against shorting

## APPLICATIONS

- Computer memory, power backup systems
- Telecommunications
- Residential, industrial and commercial security systems
- PLC and industrial controls

RETAINER COVERS



## THM LOW PROFILE



108C  
1028C  
1029LC  
RETAINER COVERS

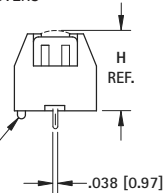

## SPECIFICATIONS

Base/Retainer Cover: PBT, UL 94V-0

Contacts: .012 (.30) Stainless Steel, Tin-Nickel Plate

Operating Temp Range: -60°F to +293°F (-51°C to +145°C)

HOLDER	COVER								CELL SIZE	PACKAGING SPECS	BATTERY CROSS REFERENCE
CAT. NO.	CAT. NO.	L	W	H (Ref. Dim)	A	B	F	G			
108	108C	1.160 (29.5)	.640 (16.3)	.633 (16.1)	1.030 (26.2)	1.360 (34.5)	.610 (15.5)	.279 (7.1)	"1/2 AA" "CR2"	50 pieces per tray Energizer 544, CR2, Duracell PX28L, CR2, Kodak K28A & KS28, CR2, Panasonic CR14250, CR2, Saft LCP3, Maxell 4LR44, CR2, Sanyo CR14250SE, CR2	
1028	1024C 1028C	2.160 (54.9)	.640 (16.3)	.633 (16.1)	2.040 (51.8)	2.360 (59.9)	1.610 (40.9)	.279 (7.1)	"AA"	50 pieces per tray Energizer, Duracell, Panasonic, Sanyo, Varta, Rayovac, Tadiran	
1029	1029C 1029LC	1.500 (38.1)	.720 (18.3)	.712 (18.1)	1.375 (34.9)	1.700 (43.2)	.950 (24.1)	.320 (8.1)	"2/3 A"	50 pieces per tray Duracell DL2/3A, Kodak K123L, Panasonic CR123A, Saft 450SC & VR0450, Sanyo CR17335SE	

## THM ULTRA LOW PROFILE

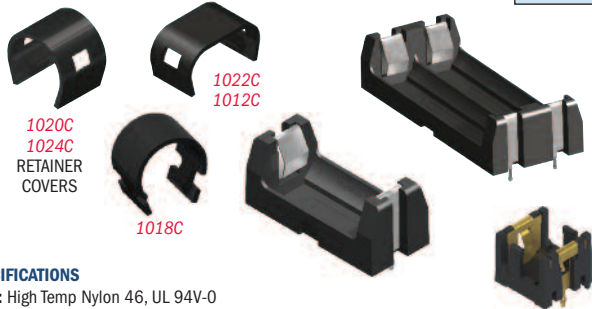

## SPECIFICATIONS

Base: High Temp Nylon 46, UL 94V-0

Contacts: .012 (.30) Stainless Steel, Tin-Nickel Plate

Operating Temp Range: -60°F to +293°F (-51°C to +145°C)

## SINGLE

Mounting Detail

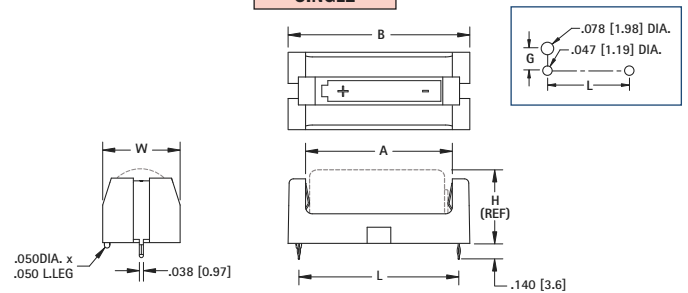

DWG. 1

## DUAL

Mounting Detail

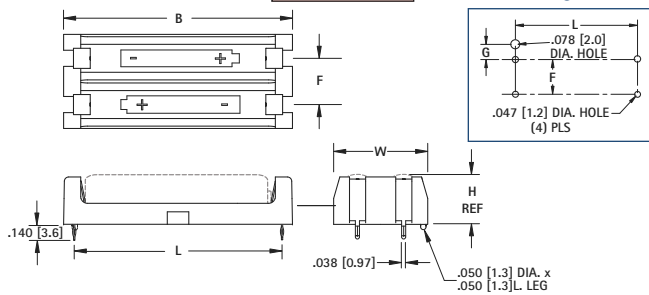

DWG. 2

## "1/3N"

Mounting Detail

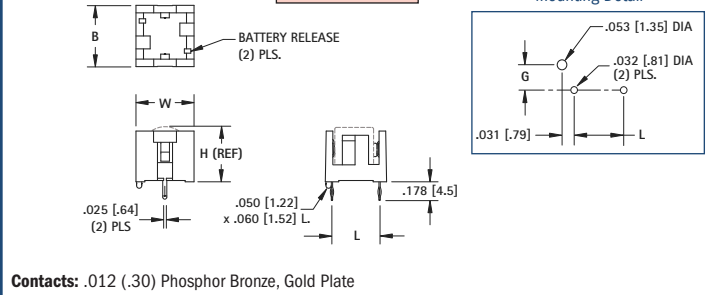

Contacts: .012 (.30) Phosphor Bronze, Gold Plate

DWG. 3

HOLDER	COVER	DWG NO.	L	W	H (Ref. Dim)	B	F	G	CELL SIZE	PACKAGING SPECS	BATTERY CROSS REFERENCE
1021	1020C	1	1.933 (49.1)	.500 (12.7)	.445 (11.3)	2.140 (54.4)	-	.209 (5.3)	"AAA"	50 pieces per tray	All Major Manufacturers
1023	1022C	2	1.933 (49.1)	.875 (22.2)	.445 (11.3)	2.140 (54.4)	.430 (10.9)	.182 (4.6)	"AAA"	25 pieces per tray	
1015	1024C	1	2.161 (54.9)	.612 (15.5)	.603 (15.3)	2.359 (59.9)	-	.265 (6.7)	"AA"	50 pieces per tray	All Major Manufacturers
1013*	1012C	2	2.161 (54.9)	1.180 (30.0)	.603 (15.3)	2.359 (59.9)	.568 (14.4)	.265 (6.7)	"AA"	25 pieces per tray	
1017	1024C	1	1.156 (29.4)	.612 (15.5)	.603 (15.3)	1.360 (34.5)	-	.265 (6.7)	"1/2 AA"	50 pieces per tray	Energizer 544, Duracell PX28L, Kodak K28A & KS28, Saft LCP3, Maxell 4LR44, Sanyo CR14250SE
1019*	1018C	1	1.487 (37.8)	.720 (18.3)	.682 (17.3)	1.690 (42.9)	-	.319 (8.1)	"2/3 A"	50 pieces per tray	Duracell DL2/3A, Kodak K123L, Saft 450SC & VR0450, Sanyo CR17335SE
1099*	-	2	1.487 (37.8)	1.440 (36.6)	.682 (17.3)	1.690 (42.9)	.720 (18.3)	.319 (8.1)	"2/3 A"	25 pieces per tray	
503	-	3	.450 (11.4)	.540 (13.7)	.506 (12.9)	.570 (14.5)	-	.240 (6.1)	"1/3 N"	300 pieces per tray	Duracell DL1/3N, Sanyo K58L, Energizer CR1/3N

\*Base Material: PBT UL 94V-0

THM BATTERY HOLDERS