



DATA SHEET



Part No.: BDC-DR

**PLCC-2 TOP LED with lens 30° Series
SMD 3528 0.1w Red Color**

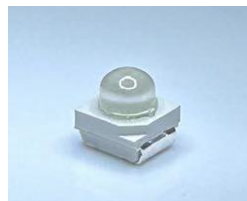

Created Date: 2022-08-16 Version 1.6

Company Address: 3F, Building C, Xing Hong Technology Park,
Shuiku Road No111, Xixiang Street, Baoan District, Shenzhen, China .
Company TEL: +86-755-83467896
<http://www.bndlight.com>

Features

- Red Color PLCC-2 Package
- InGaAlP Chip
- View angle at 50% Iv of 30°
- Corrosion Robustness: Excellent corrosion robustness
- Suitable for SMT process
- Available on tape and reel

Applications

- Auto Signaling
- Auto Lighting Interior and Exterior
- Signal and Symbol Luminary



Product Nomenclature

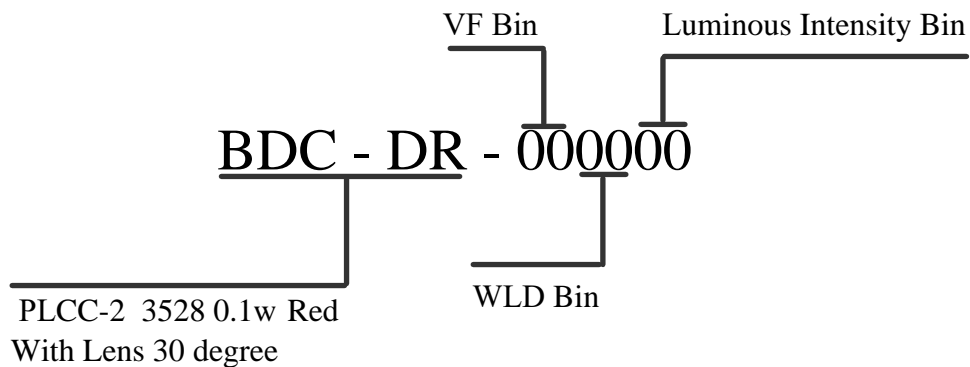

Ordering Information

Type	Luminous Intensity @20mA			Unit
	Min.	Typ.	Max.	
BDC-DR-000000	2290	/	5740	mcd

Maximum Ratings $T_s=25^{\circ}\text{C}$, RH60%

Parameter	Symbol	Values	Unit
Operating Temperature	T_{op}	-40~+100	$^{\circ}\text{C}$
Storage Temperature	T_{stg}	-40~+100	$^{\circ}\text{C}$
Junction Temperature	T_j	125	$^{\circ}\text{C}$
Forward Current ($T_s=25^{\circ}\text{C}$)	I_F	50	mA
Surge Current ($t \leq 10\mu\text{s}$; $D=0.1$; $T_s=25^{\circ}\text{C}$)	I_{FS}	100	mA
Reverse Voltage ($T_s=25^{\circ}\text{C}$)	V_R	5	V
Electrostatic Discharge (acc.to ANSI/ESDA/JEDEC JS-001-2017)	V_{ESD}	≥ 2	kV

Optical & Electrical Characteristics $I_F=20\text{mA}$, $T_s=25^\circ\text{C}$, RH60%

Item	Symbol	Min.	Typ.	Max.	Unit
Peak Wavelength	λ_{peak}	/	632	/	nm
Dominant wavelength	λ_{dom}	620	/	628	nm
Spectral bandwidth at 50% IV	$\Delta\lambda$	/	16	/	nm
Viewing Angle	$2\theta_{1/2}$	/	30	/	Deg
Forward Voltage	V_F	1.8	/	2.4	V
Reverse Current	$I_R (V_R=5V)$	/	0.2	10	μA
Thermal Resistance junction/solderpoint	$R_{\text{th}(j\text{-sp})\text{real}}$	/	116	143	K/W
Electrical Thermal Resistance junction/solderpoint with efficiency $\eta=32\%$	$R_{\text{th}(j\text{-sp})\text{elec.}}$	/	79	103	K/W

Forward Voltage Rank

Bin Code	Va	Vb	Vc	Vd
Forward Voltage/V	1.8-1.95	1.95-2.1	2.1-2.25	2.25-2.4

- Tolerance of measurements of the Forward is $\pm 0.05V$
- $I_F=20mA$, $T_S=25^\circ C$, $RH60\%$

Dominant Wavelength Rank

Bin Code	WG	WH
WLD/nm	620-624	624-628

- Tolerance of measurements of the DWL is $\pm 1.5nm$
- $I_F=20mA$, $T_S=25^\circ C$, $RH60\%$

Luminous Intensity Rank

Bin Code	FD	FS	FT	FU	FV
Luminous Intensity/mcd	2290-2880	2880-3560	3560-4230	4230-4850	4850-5740

- Tolerance of measurements of the Luminous Intensity is $\pm 8\%$
- $I_F=20mA$, $T_S=25^\circ C$, $RH60\%$

Optical & Electrical Characteristics Curves

$I_F=20mA$, $T_s=25^\circ C$, $RH60\%$

Fig.1 Relative Spectral Emission

$I_{rel} = f(\lambda)$

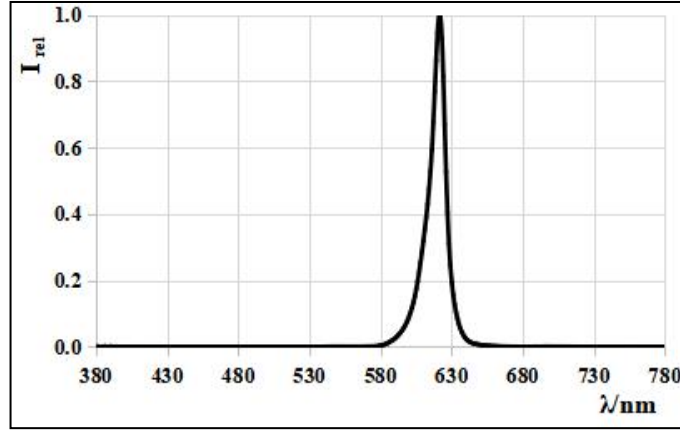

Fig.2 Forward Current Vs. Relative Intensity

$\Phi_V/\Phi_V(20mA) = f(I_F)$

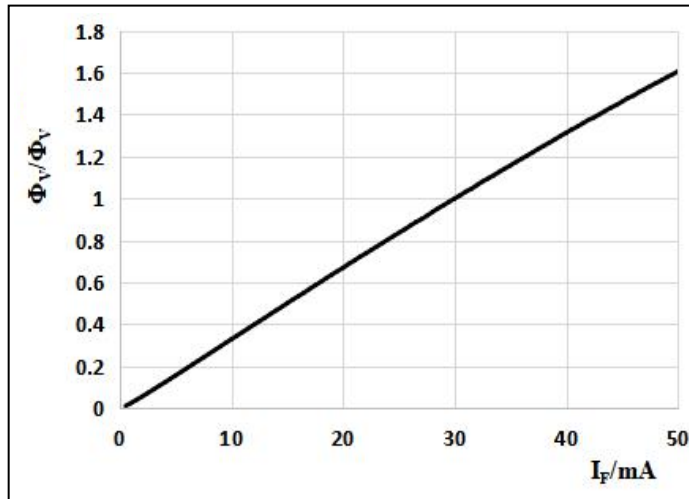

Fig.3 Forward Voltage Vs. Forward Current

$I_F = f(V_F)$

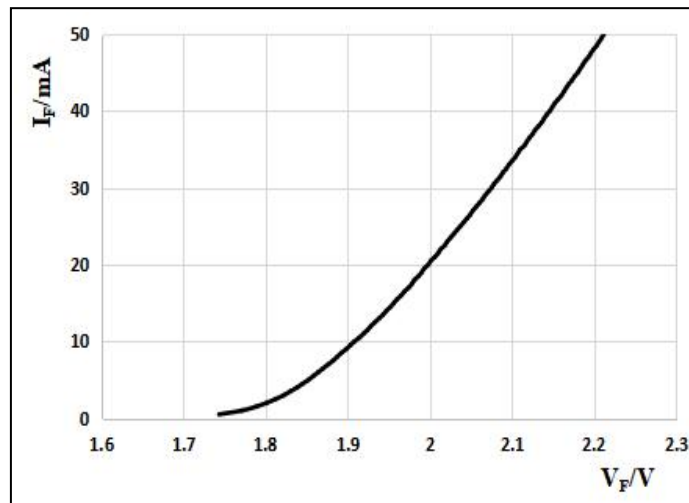

Fig 4. Junction Temperature Vs. Relative Intensity

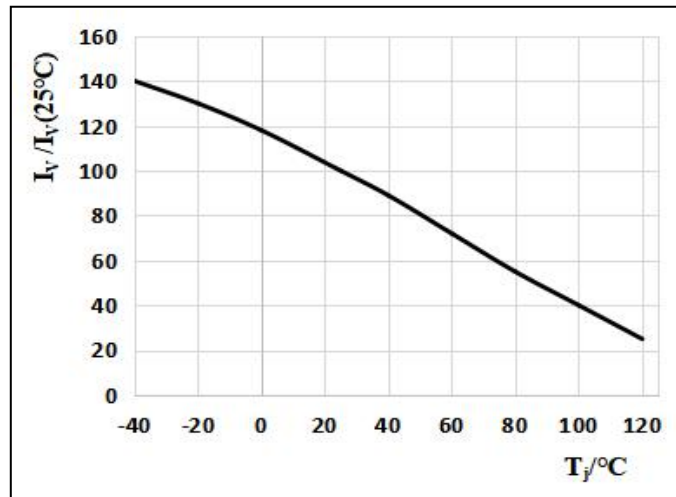

Fig 5. Junction Temperature Vs. ΔV_F

$\Delta V_F = V_F - V_F(25^\circ\text{C}) = f(T_j)$

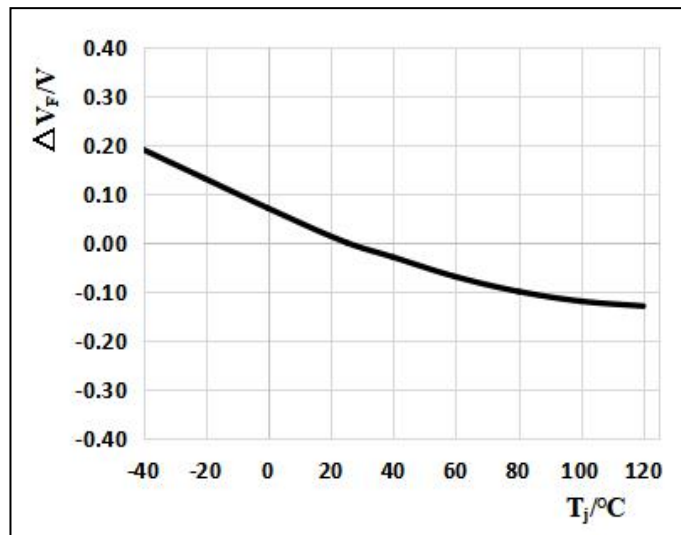

Fig 6. Junction Temperature Vs. $\Delta\lambda_{\text{dom}}$

$\Delta\lambda_{\text{dom}} = \lambda_{\text{dom}} - \lambda_{\text{dom}}(25^\circ\text{C}) = f(T_j)$

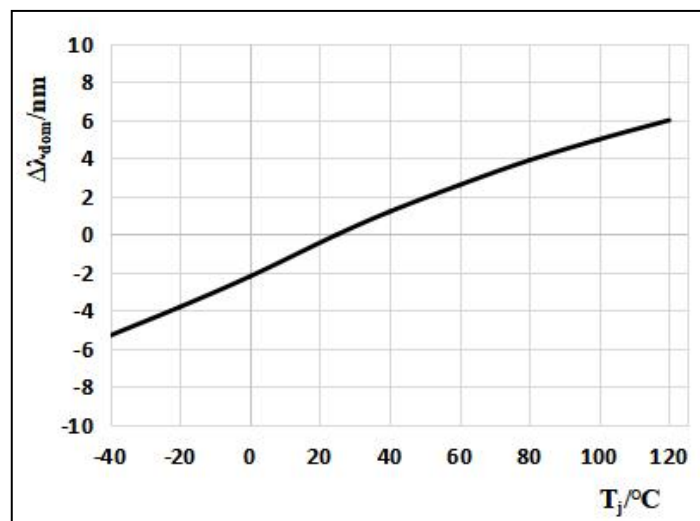

Fig 7. Ts Vs. Max. Permissible IF

$I_F = f(T_s)$

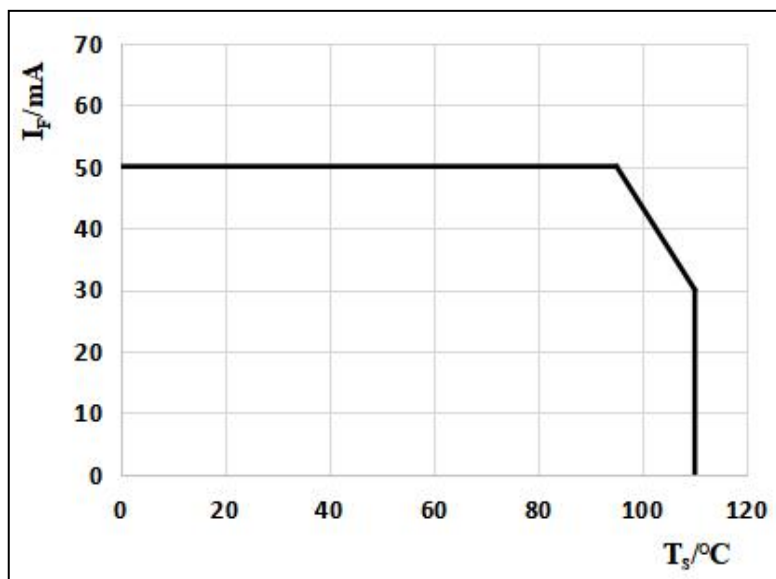
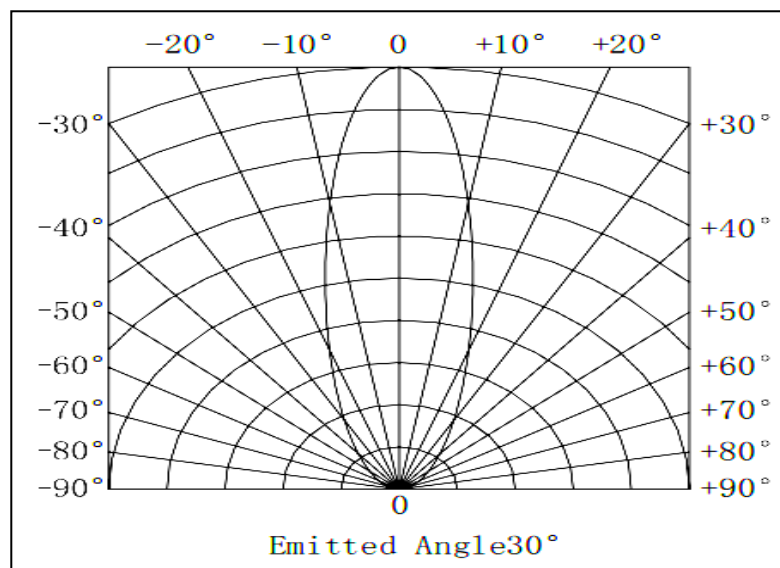

Fig 8. Radiation diagram

$I_{rel} = f(\Phi)$



Reflow Soldering Characteristics

Product complies to MSL Level 2a acc. To JEDEC J-STD-020 D.01

Reflow soldering	
Temperature Min (T _{smin})	150° C
Temperature Max (T _{smax})	200° C
Time(ts)from (T _{smin} to T _{smax})	60-120 seconds.
Ramp-up rate (TL to T _p)	3° C/seconds max.
Liquidous temperature(TL)	217° C
Time(ts) maintained above TL	60-150 seconds
Peak package body temperature(T _p)	260° C max
Time (t _p) within 5° C of the specified classification temperature(T _c).	30 seconds max
Ramp-down rate (T _p to TL)	6° C/second max
Time 25° C to peak temperature	8 min max

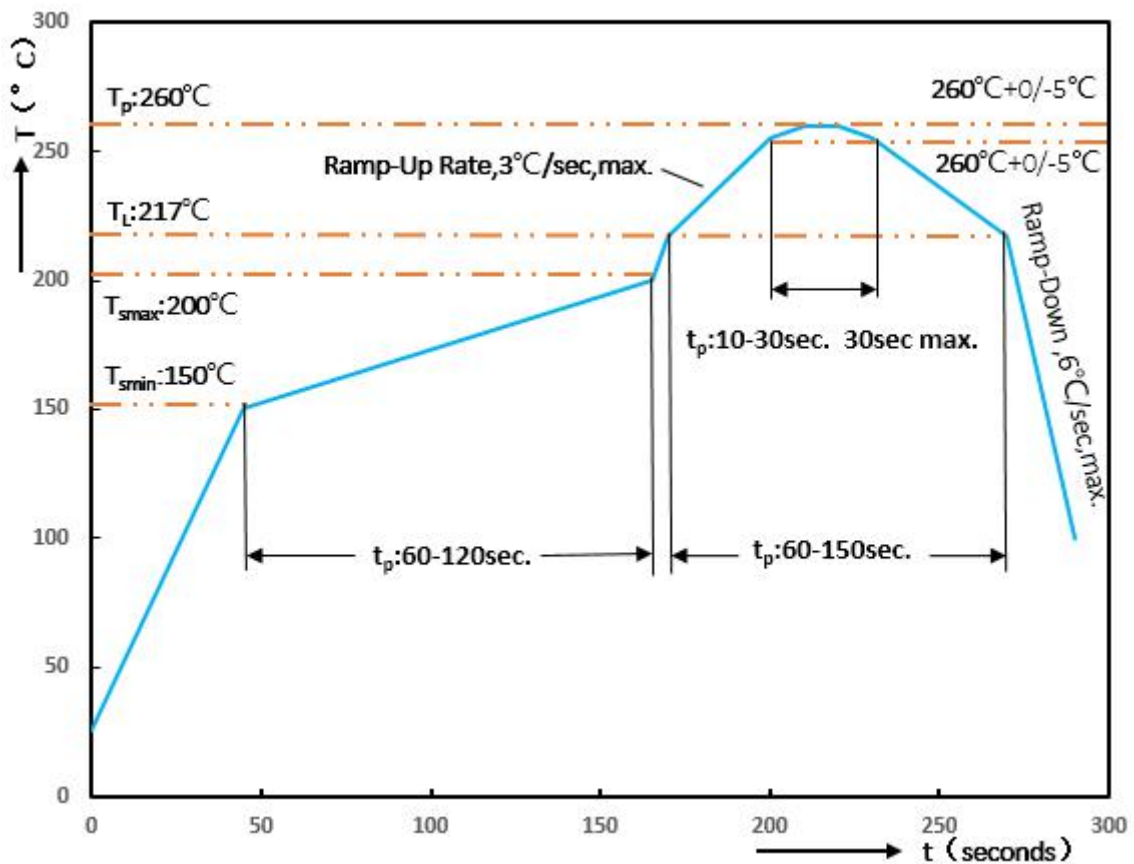

Mechanical Dimensions

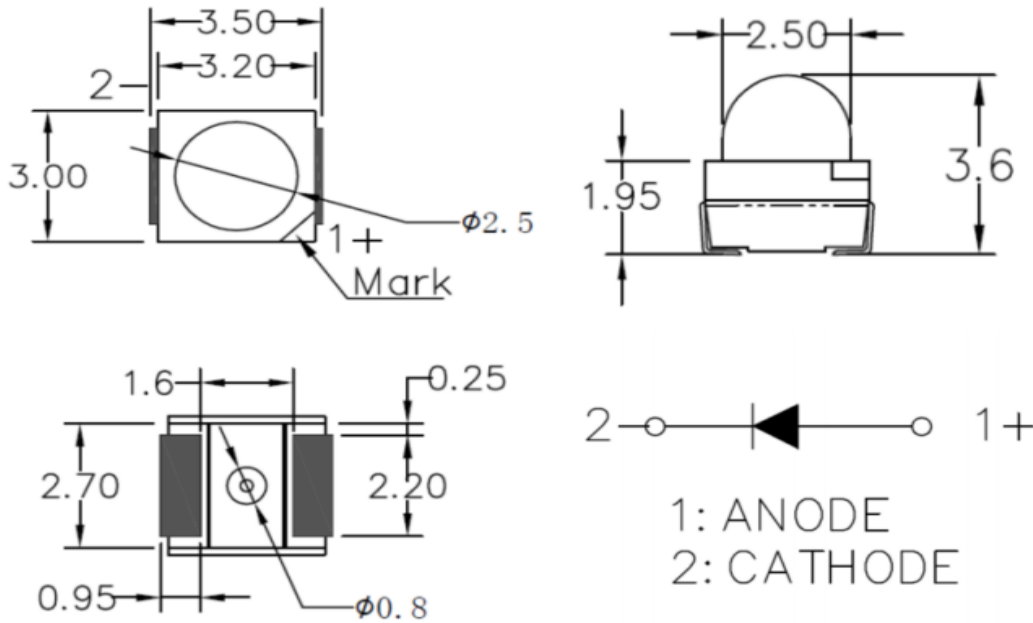

- All dimensions are in millimeters
- Tolerance is $\pm 0.1\text{mm}$, unless otherwise noted
- Approximate Weight: 40.0mg

Recommended Solder Pad

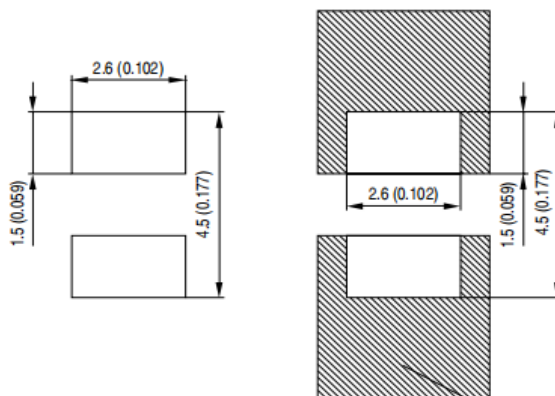

- All dimensions are in millimeters
- Tolerance is $\pm 0.1\text{mm}$, unless otherwise noted

Packaging Information

(1) Label

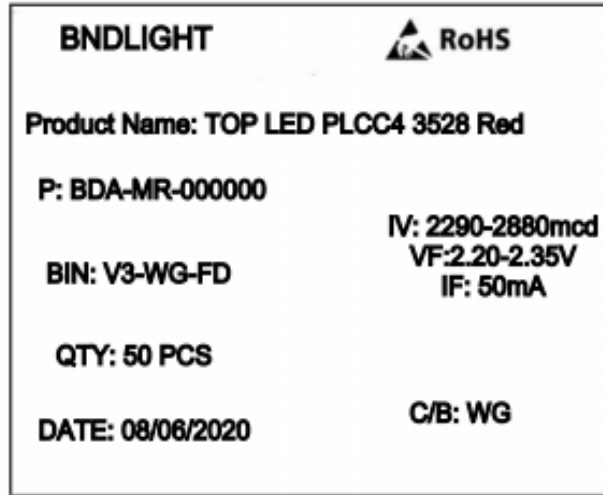

(2) Tape spec

Unit: mm

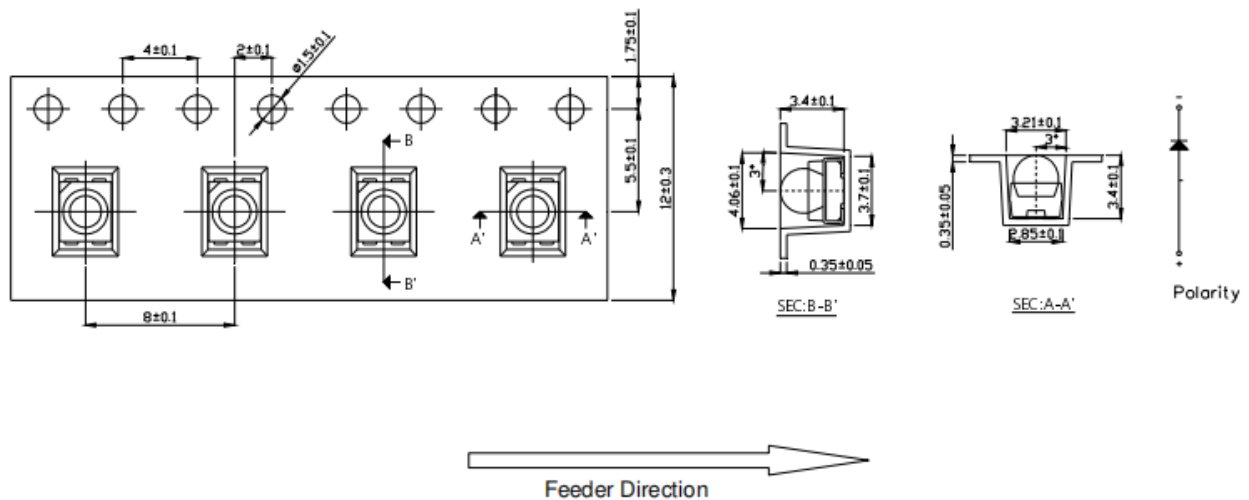

- Quantity : 2000pcs/Reel
- Cumulative Tolerance : Cumulative Tolerance/10 pitches to be $\pm 0.2\text{mm}$
- Adhesion Strength of Cover Tape Adhesion strength to be 0.1-0.7N when the cover tape is turned off from the carrier tape at the angle of 10° to the carrier tape.
- Package : P/N, Manufacturing data Code No. and Quantity to be indicated on a damp proof Package.

(3) Reel Dimensions

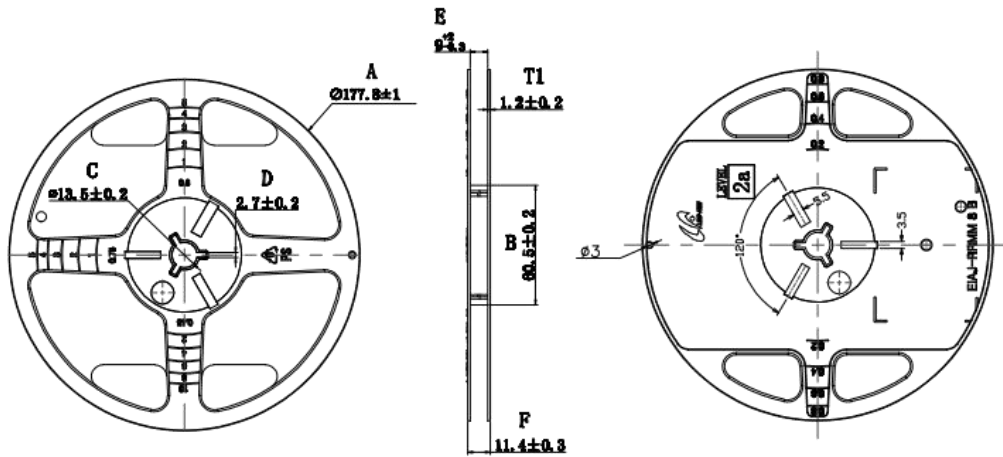

(4) Moisture Resistant Package

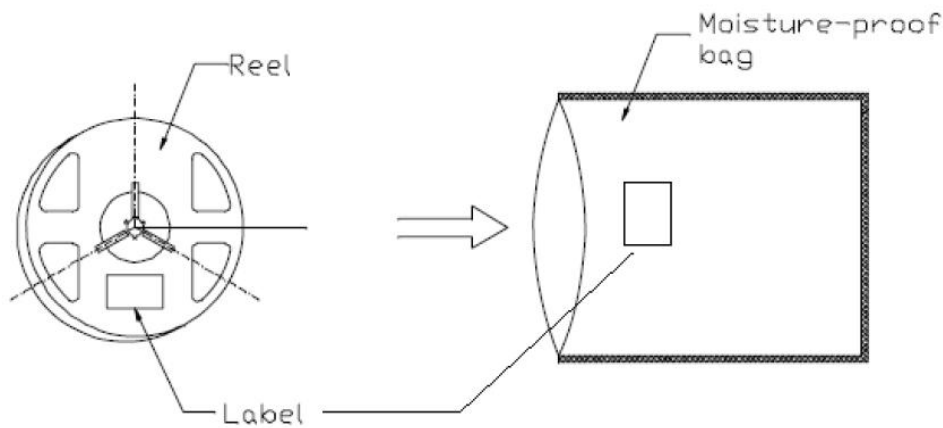

(5) Package Box

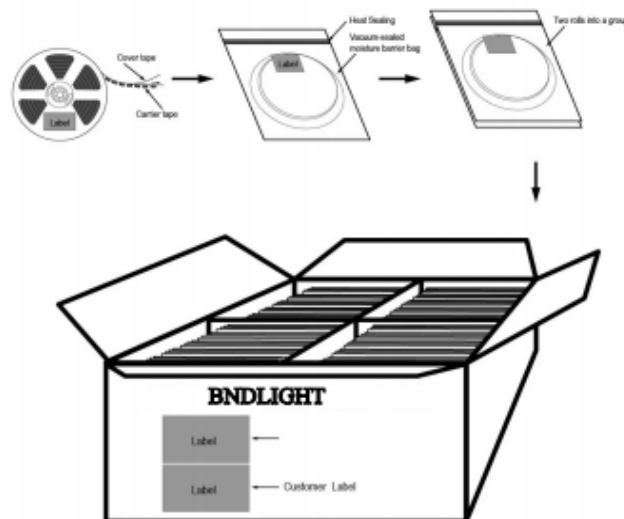

Application notes

1) Storage

To avoid the moisture penetration, we recommend store in a dry box with a desiccant, The maximum storage temperature range is 40°C and a maximum humidity of RH60%.

2) Use Precaution after Opening the Packaging

Recommend conditions after opening the package

-Sealing

-Temperature : 30°C Humidity : Less than RH50%

-Recommend to use up before 72hrs after opening the package.

3) If the package has been opened more than 4 weeks(MSL_2a) or the color desiccant changes, LED Components should be dried for 12hrs at 60±5°C. .

4) Do not apply mechanical force or excess vibration during the cooling process to normal temperature after soldering.

5) Do not rapidly cool device after soldering.

6) The LED should not be mounted on warped portion of PCB.

7) The LED should not be used in any type of fluid such as water, oil, organic solvent and etc. When washing is required, IPA (Isopropyl Alcohol) should be used.

8) When the LEDs are in operation the maximum current should be decided after measuring the package temperature.

9) Long time exposure of sunlight or occasional UV exposure will cause lens discoloration.

10) The driving circuit must be designed to allow forward voltage only when it is ON or OFF. If the reverse voltage is applied to LED, migration can be generated resulting in LED damage.

11) LEDs are sensitive to Electro-Static Discharge (ESD). Below is a list of suggestions that BND purposes to minimize these effects.

The products are sensitive to static electricity or surge voltage. ESD can damage a die and it's Reliability. When handing the products, the following measures against electrostatic discharge are strongly recommended:

-Increase in reverse leakage current lowered turn-on voltage

-Abnormal emissions from the LED at low current LED

The following recommendations are suggested to help minimize the potential for an ESD event. One or more recommended work area suggestions:

-Dissipating static charge with conductive materials

-Preventing charge generation with moisture

-ESD safe storage containers ESD

One or more personnel suggestion options:

-Antistatic wrist-strap

-Antistatic material shoes

-Antistatic clothes

Environmental controls:

-Humidity control (ESD gets worse in a dry environment)

12) Handling Precautions

During processing, mechanical stress on the surface should be minimized as much as possible. Sharp objects of all types should not be used to pierce the sealing compound.

In general, LEDs should only be handled from the side. By the way, this also applies to LEDs Without a silicone sealant, since the surface can also become scratched.

BND suggests using isopropyl alcohol for cleaning. In case other solvents are used, it must be assured that these solvents do not dissolve the package or resin.

Please do not mold this products into another resin (epoxy, urethane, etc.) and do not handle this Product with acid or sulfur material in sealed space.

Notes

The evaluation of eye safety occurs according to the standard IEC 62471:2006 (photo biological safety of lamps and lamp systems). Within the risk grouping system of this IEC standard, the device specified in this data sheet falls into the class exempt group (exposure time 10000 s). Under real circumstances (for exposure time, conditions of the eye pupils, observation distance), it is assumed that no endangerment to the eye exists from these devices. As a matter of principle, however, it should be mentioned that intense light sources have a high secondary exposure potential due to their blinding effect. When looking at bright light sources (e.g. headlights), temporary reduction in visual acuity and afterimages can occur, leading to irritation, annoyance, visual impairment, and even accidents, depending on the situation.

Subcomponents of this device contain, in addition to other substances, metal filed materials including silver. Metal filed materials can be affected by environments that contain traces of aggressive substances. Therefore, we recommend that customers minimize device exposure to aggressive substances during storage, production, and use. Devices that showed visible discoloration when tested using the described tests above did show no performance deviations within failure limits during the stated test duration. Respective failure limits are described in the IEC60810.

Disclaimer

1) Attention please

The information describes the type of component should not be considered as assured characteristics. Terms of delivery and rights to change design reserved. Due to technical requirements components may contain dangerous substances.

For information on the types in question please contact our Sales Organization.

2) Product and functional safety devices/applications or medical devices/applications

The components are not developed, constructed or tested for the application as safety relevant component or for the application in medical devices.

Glossary

- 1) Brightness: Brightness values are measured during a current pulse of typically 20ms, with an internal reproducibility of $\pm 5\%$.
- 2) Wavelength: The wavelength is measured at a current pulse of typically 20ms, with an internal reproducibility of $\pm 1.5\text{ nm}$.
- 3) Forward Voltage: The forward voltage is measured during a current pulse of typically 20ms, with an internal reproducibility of $\pm 0.05\text{ V}$.
- 4) Reverse Operation: Continuous reverse operation is not allowed
- 5) Thermal Resistance: R_{thJA} results from mounting on PC board.
- 6) Typical Values: Due to the special conditions of the manufacturing processes of semiconductor devices, the typical data or calculated correlations of technical parameters can only reflect statistical figures. These do not necessarily correspond to the actual parameters of each single product, which could differ from the typical data and calculated correlations or the typical characteristic line. If requested, e.g. because of technical improvements, these typ. data will be changed without any further notice.
- 7) Characteristic curve: In the range where the line of the graph is broken, you must expect higher differences between single devices within one packing unit.