

Matter Module Specification

HM-MT2401

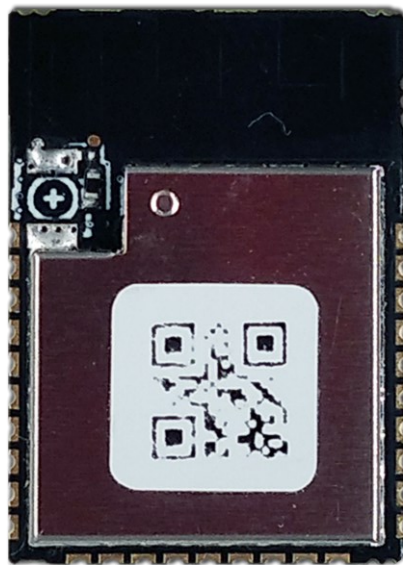

Table of Contents

1	Product Overview	3
2	Module Features	3
3	Electrical Characteristics	4
4	Module Function Description	5
5	Module Application Example	6
6	Module Interfaces	7
	6.1 Module Footprint.....	7
	6.2 Pin Definition	8
7	Module Dimensions	9
8	Hardware Design Considerations	10
9	Frequently Asked Questions	12
	9.1 An unsatisfactory transmission distance.....	12
	9.2 Easy to damage —— abnormal damage	13
	9.3 The BER rate is too high	13
10	Reflux Welding Conditions.....	14
11	Electrostatic Discharge Warning	15
12	Document Change Record.....	15
13	Contact Information	15

1 Product Overview

The HM-MT2401 is a Matter over Thread wireless communication module based on the 2.4 GHz frequency band. It includes a high-performance, highly integrated RF processing chip EFR32MG24, inside a low-power 32-bit ARM® Cortex®-M33 core, 1536kB Flash, 256kB RAM, and rich in peripheral resources, equipped with an integrated PCB antenna and an external antenna holder, support for wireless communication technologies such as Matter, Thread, and BLE. The HM-MT2401 can be used to develop the Matter over Thread end device, enabling the original non-Matter wireless devices can be easily upgraded to Smart Home devices that meet Matter standards.

2 Module Features

- High-performance 32-bit 78.0 MHz ARM® Cortex®-M33 with DSP instructions and floating-point unit for efficient signal processing
- Support Matter, OpenThread, Zigbee, Bluetooth Low Energy (BLE 5.3), Multi-protocol
- 1536 kB FLASH program memory and 256 KB RAM data memory
- 2.4 GHz radio operation
- Secure Vault
 - Hardware Cryptographic Acceleration for AES128/192/256, ChaCha20-Poly1305, SHA-1, SHA-2/256/384/512, ECDSA+ECDH(P-192, P-256, P-384, P-521), Ed25519 and Curve25519, J-PAKE, PBKDF2
 - True Random Number Generator (TRNG)
 - ARM® TrustZone®
 - Secure Boot (Root of Trust Secure Loader)
 - Secure Debug Unlock

- DPA Countermeasures
- Secure Key Management with PUF
- Anti-Tamper
- Secure Attestation
- Wide selection of MCU peripheral devices
- Support for the internal RTC live clock
- Certified by FCC / CE / IC / SRRC
- Compliance with the ROHS / REACH / CA Prop 65 standards

3 Electrical Characteristics

- Operating voltage range: 1.71V to 3.8V
- Operating temperature range: -40°C ~ +125°C
- Modulation mode: 2 (G) FSK with fully configuration shaping, OQPSK DSSS, (G) MSK
- Modulation frequency: 2402MHz-2483.5MHz
- Receiving sensitivity:
 - -105.4-dBm sensitivity @ 250 kbps O-QPSK DSSS
 - -105.7 dBm sensitivity @ 125 kbps GFSK
 - -97.6 dBm sensitivity @ 1 Mbps GFSK
 - -94.8 dBm sensitivity @ 2 Mbps GFSK
- TX Power up to + 19.5 dBm
- Low system energy consumption:
 - 4.4 mA RX current (1 Mbps GFSK)
 - 5.1 mA RX current (250 kbps O-QPSK DSSS)
 - 5 mA TX current @ 0 dBm output power
 - 19.1 mA TX current @ 10 dBm output power
 - 156.8 mA TX current @ 19.5 dBm output power
 - 33.4 μ A/MHz in Active Mode (EM0) at 39.0 MHz

- 1.3 μ A EM2 Deep Sleep current (16 kB RAM retention and RTC running from LFRCO)

4 Module Function Description

Through a simple interface design to integrate the HM-MT2401 module into Smart Home end devices (such as lighting, switches, plugs, door locks, curtain motors, doorbells, thermostats, temperature sensors, and other end devices), the original end device can be upgraded to Matter devices that meet the Matter standard specifications. Users can scan the QR code of the Matter device through the Smart Home App such as Apple Home App. After several simple steps, the users can easily commission the Matter device through BLE, to add it to the existing Matter network. The Matter devices developed based on the HM-MT2401 module can be seamlessly added to the Smart Home ecosystems such as Google Home, Apple Homekit, Amazon Alexa, and Samsung SmartThings, greatly simplifying the customer product development cycle, accelerating the product launch, and effectively improving the user experiences.

5 Module Application Example

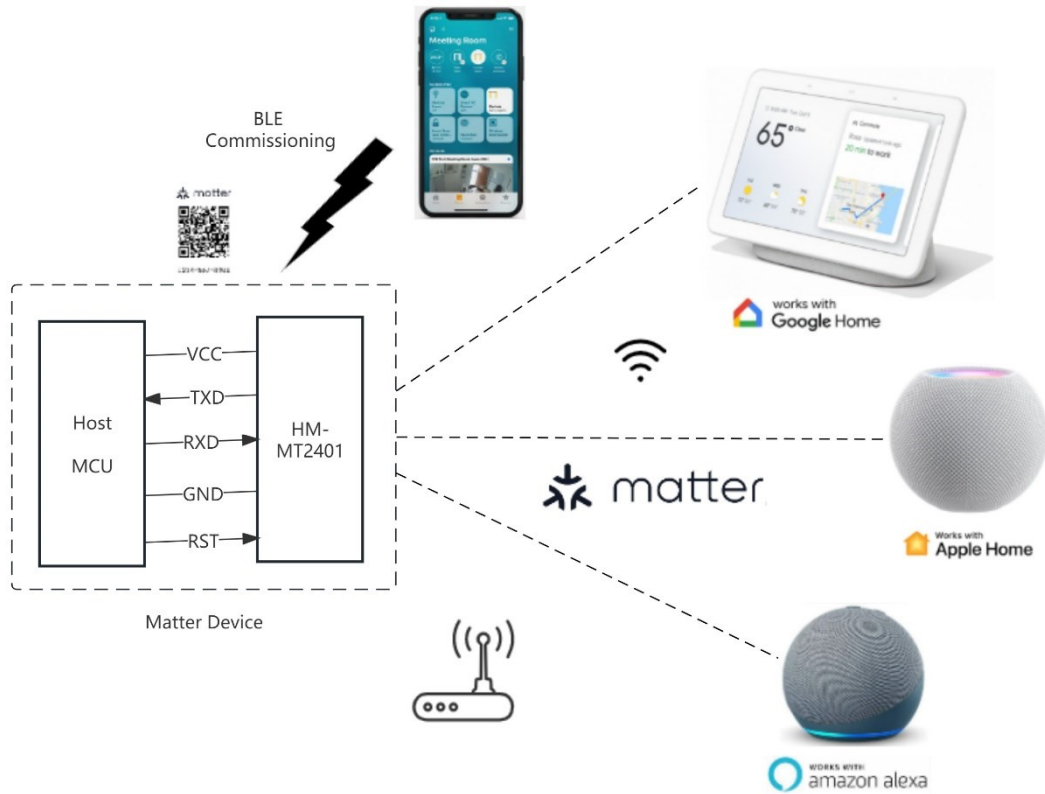

Figure 1 One of the application example for the module

6 Module Interfaces

6.1 Module Footprint

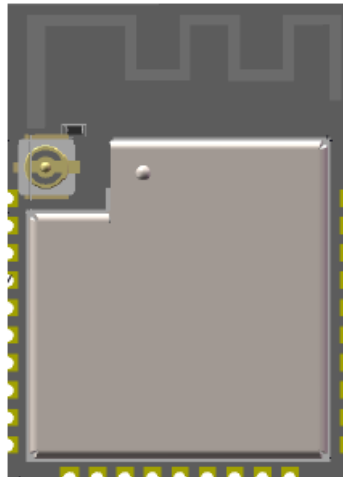

Figure 2 Top View

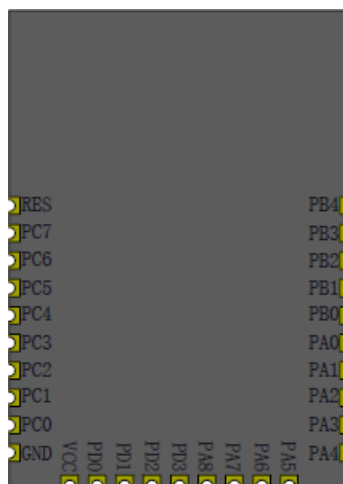

Figure 3 Bottom View

6.2 Pin Definition

Pin No.	Pin Name	Type	Description
1	PB4	I/O	GPIO
2	PB3	I/O	GPIO
3	PB2	I/O	GPIO
4	PB1	I/O	GPIO
5	PB0	I/O	GPIO
6	PA0	I/O	GPIO
7	PA1	I/O	SWCLK
8	PA2	I/O	SWDIO
9	PA3	I/O	GPIO
10	PA4	I/O	GPIO
11	PA5	DO	PA5; UART TXD
12	PA6	DI	PA6; UART RXD
13	PA7	I/O	GPIO
14	PA8	I/O	GPIO
15	PD3	I/O	GPIO
16	PD2	I/O	GPIO
17	PD1	I/O	GPIO
18	PD0	I/O	GPIO
19	VCC	DV	Power supply
20	GND	DG	Ground
21	PC0	I/O	GPIO
22	PC1	I/O	GPIO
23	PC2	I/O	GPIO
24	PC3	I/O	GPIO
25	PC4	I/O	GPIO

26	PC5	I/O	GPIO
27	PC6	I/O	GPIO
28	PC7	I/O	GPIO
29	RES	I/O	Reset

Table 1 HM-MT2401 Module Pin Definitions

7 Module Dimensions

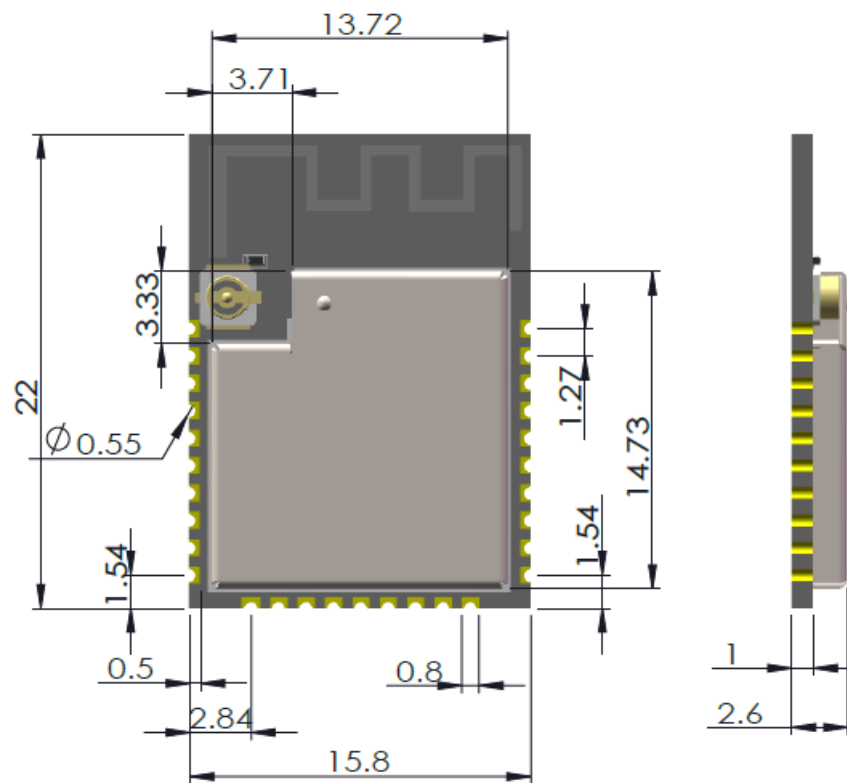

Figure 4 Module dimensions of HM-MT2401 with shield cover

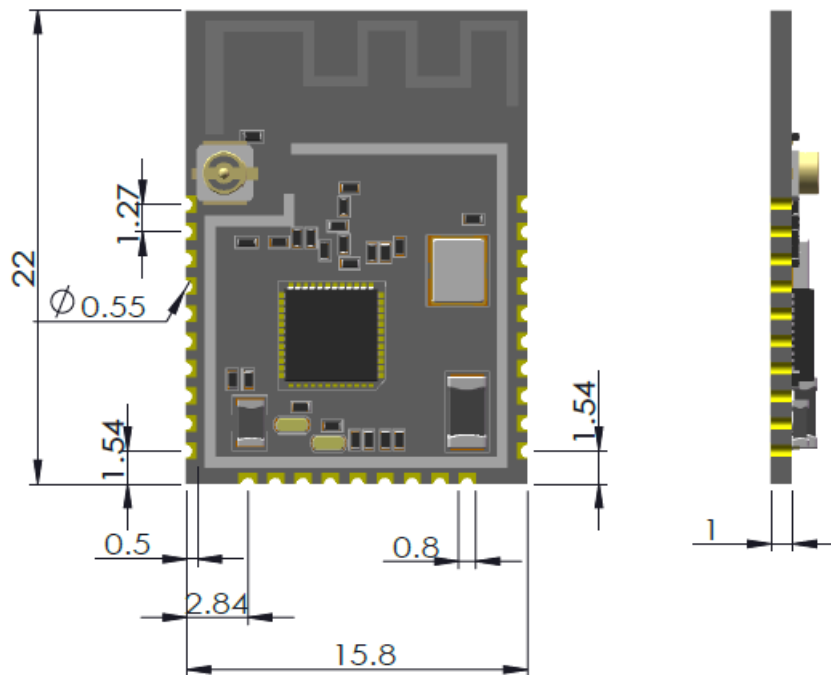

Figure 5 Module dimensions of HM-MT2401 without shield cover

8 Hardware Design Considerations

1. It is recommended to supply the module with DC voltage power supply as small as possible and the module should be reliably grounded; Please pay attention to the correct connection of the positive and negative poles of the power supply, if the reverse connection may cause permanent damage to the module;
2. Please check the power supply to ensure that exceeding the maximum value will cause permanent damage to the module; Please check the stability of the power supply and the voltage cannot fluctuate substantially and frequently;
3. When designing the power supply circuit for the module, it is recommended to keep more than 30% allowance, which is conducive to the long-term stable

operation of the whole machine; The module should keep away from the parts with large electromagnetic interference such as power supply, transformer, and high-frequency wiring;

4. High-frequency digital routing, high-frequency analog wiring, and power wiring must avoid below the module, if have to go through the module, assuming that the module is welded in the Top Layer, Top Layer in the contact part of the module (all copper and good grounding), wiring must be close to the digital part of the module, and line in Bottom Layer;

5. Assuming that the module is welded or placed in Top Layer, it is wrong to walk at the Bottom Layer or other layers, which will affect the stray and receiving sensitivity of the module to different degrees;

6. Assuming that there are devices with large electromagnetic interference around the module will also greatly affect the performance of the module, according to the strength of the interference, it is recommended to stay away from the module, if the situation allows, appropriate isolation and shielding can be done;

7. Suppose that there is a wiring around the module with large electromagnetic interference (high-frequency digital, high-frequency simulation, power wiring) that will also greatly affect the performance of the module. According to the strength of interference, it is recommended to stay away from the module, and appropriate isolation and shielding can be done;

8. If the communication line uses a 5V level, the level conversion circuit must be used;

9. Keep away from some TTLs with 2.4 GHz bands, such as USB 3.0;

10. Refer to the following figure for the module antenna layout:

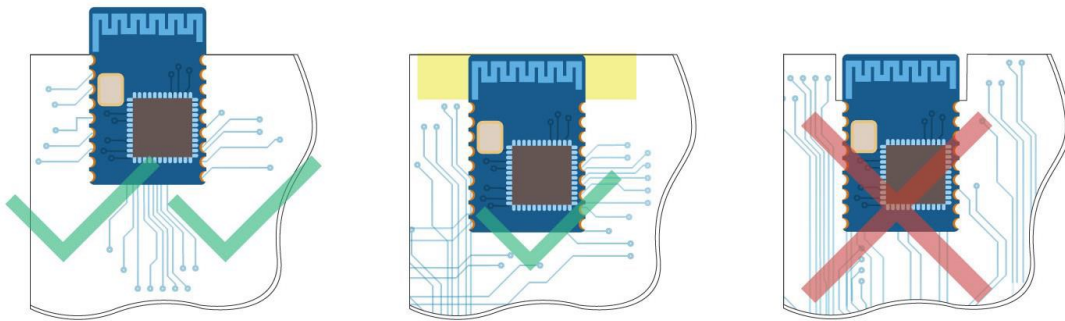

Figure 6. PCB routing recommendations

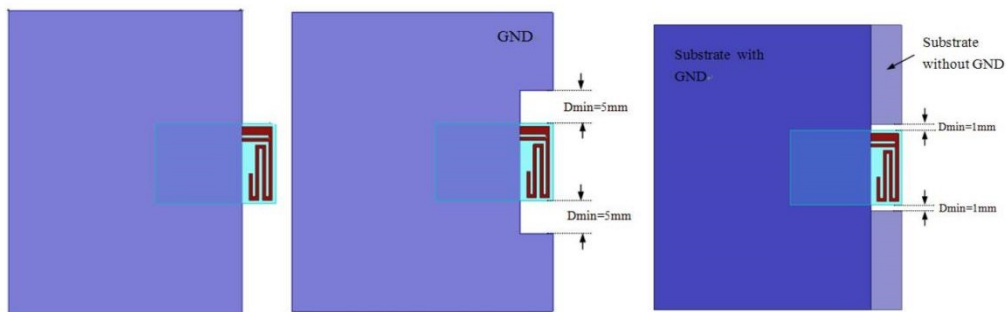

Figure 7. PCB layout recommendations

9 Frequently Asked Questions

9.1 An unsatisfactory transmission distance

1. When there is a linear communication obstacle, the communication distance will decay accordingly; Temperature, humidity, and same frequency interference will increase the communication packet loss rate; Poor ground absorbs and reflect radio waves, close to the ground;
2. The seawater has a strong ability to absorb radio waves, so the seaside test effect is poor;

3. There are metal objects near the antenna or placed in the metal shell, the signal attenuation will be very serious;
4. The power register setting is wrong and the air rate setting is too high (the higher the air rate, the closer the distance);
5. At room temperature, the power supply voltage is lower than the recommended value, and the lower the voltage, the lower the transmitting power;
6. The matching degree of the antenna and the module is poor, or the quality of the antenna itself is problematic.

9.2 Easy to damage —— abnormal damage

1. Please check the power supply to ensure that exceeding the maximum value will cause permanent damage to the module; Please check the stability of the power supply and the voltage cannot fluctuate substantially and frequently;
2. Please ensure the anti-static operation during the installation and use, and the high-frequency devices are electrostatic sensitive devices;
3. Please ensure that the humidity should not too high during the installation and use, and some components are humidity-sensitive devices; If there are no special requirements, it is not recommended to use them at too high or too low a temperature.

9.3 The BER rate is too high

1. Have the same frequency signal interference nearby, stay away from the interference source, or modify the frequency and channel to avoid the interference;

2. The power supply is not ideal and may also cause code jumble, be sure to ensure the reliability of the power supply;
3. The extension line, feeder quality is too poor or too long, and will also cause a high bit error rate.

10 Reflux Welding Conditions

1. Heating method: conventional convection or IR convection;
2. Number of allowable reflow welding: 2 times, based on the following reflow welding (conditions) (see the figure below);
3. Temperature curve: reflow welding should follow the following temperature curve (see the following figure);
4. Maximum temperature: 245°C.

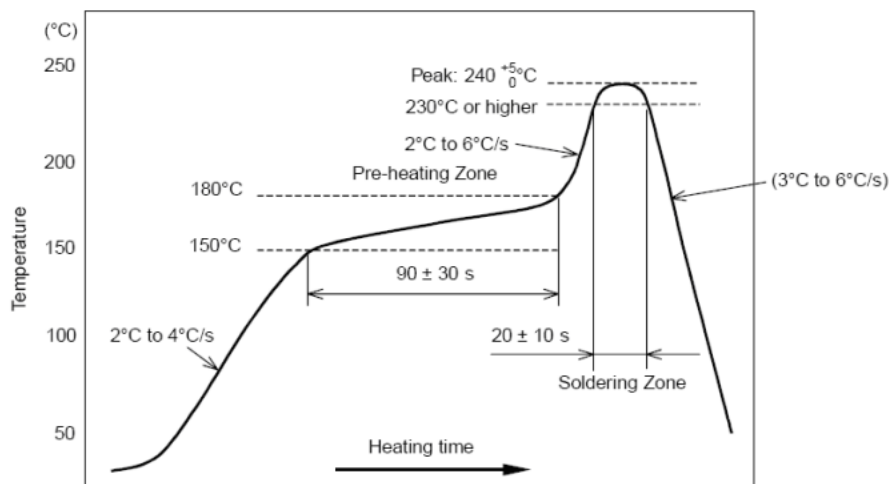

**Fig. 8 Welding heat resistance temperature curve of components
(welding points)**

11 Electrostatic Discharge Warning

The module is damaged due to static release and it is recommended that all modules be treated under the following 3 precautions:

1. Must follow the anti-static measures, can not hold the module.
2. The module must be placed in a placement area that can prevent static electricity.
3. The antistatic circuit at the high-voltage input or high-frequency input should be considered in the product design.

Electrostatics may result in subtle performance degradation to the entire device failure. Because very small parameter changes may cause the device to not meet the value limit of its certification requirements, the module will be more vulnerable to damage.

12 Document Change Record

Table 2. Document change record

Document version	Change description	Date updated
V1.0	First release	2023.7.23

13 Contact Information

Shenzhen Hope Microelectronics Co., Ltd.

Address: 30th floor of 8th Building, C Zone, Vanke Cloud City, Xili Sub-district, Nanshan, Shenzhen, GD, P.R. China

Tel: + 86-0755-82973805

Email: sales@hoperf.com

Website: <https://www.hoperf.com/>