

VECO VANSONIC ENTERPRISE CO., LTD.

8F., No.7, Lane 16, Sec.2, Szechwan Road, Panchiao, Taipei Hsien, TAIWAN.

TEL: +886-2-29626335 FAX: +886-2-29625220 E-MAIL: vansonic@ms4.hinet.net

1.	MODEL:	40DS08GE-1 -M75NT(Clear Mylar)-M75ND(Black Mylar)
2.	Dimension	Outer Diameter 40 mm. Baffle Opening ϕ 38.4 mm.
		Height Refer to Drawing Weight 6.2 Grams.
3.	Magnet	Materials Rare Earth Size ϕ 12.5x1.5 mm.
4.	Nominal Impedance	8 Ω \pm 15 % At 1000 Hz.
5.	Power Rating	Normal 0.5 W. Maximum 1 W.
6.	Lowest Resonant Frequency	420 \pm 20 % Hz.
7.	Output Sound Pressure Level (S.P.L.)	85 \pm 3 db / 0.5 Watt ; D 0.5 Meter.
		Average at 800, 1000, 1200, 1500 Hz.
8.	Frequency Range	250 ~ 20000 Hz. Average SPL - 10 db.
9.	Distortion	5 % Maximum At 1000 Hz. 500 mW.
10.	Abnormal Sound Test	Must be Normal Tested By 2 Volts. Sine Wave.
11.	Load Test	White Noise with Weighted Filter 2 Volts.(RMS) 24 Hrs.
12.	Polarity	Diaphragm shall move Forward when Apply a Positive DC.
		Current to the "+" or "Marked" Terminal.

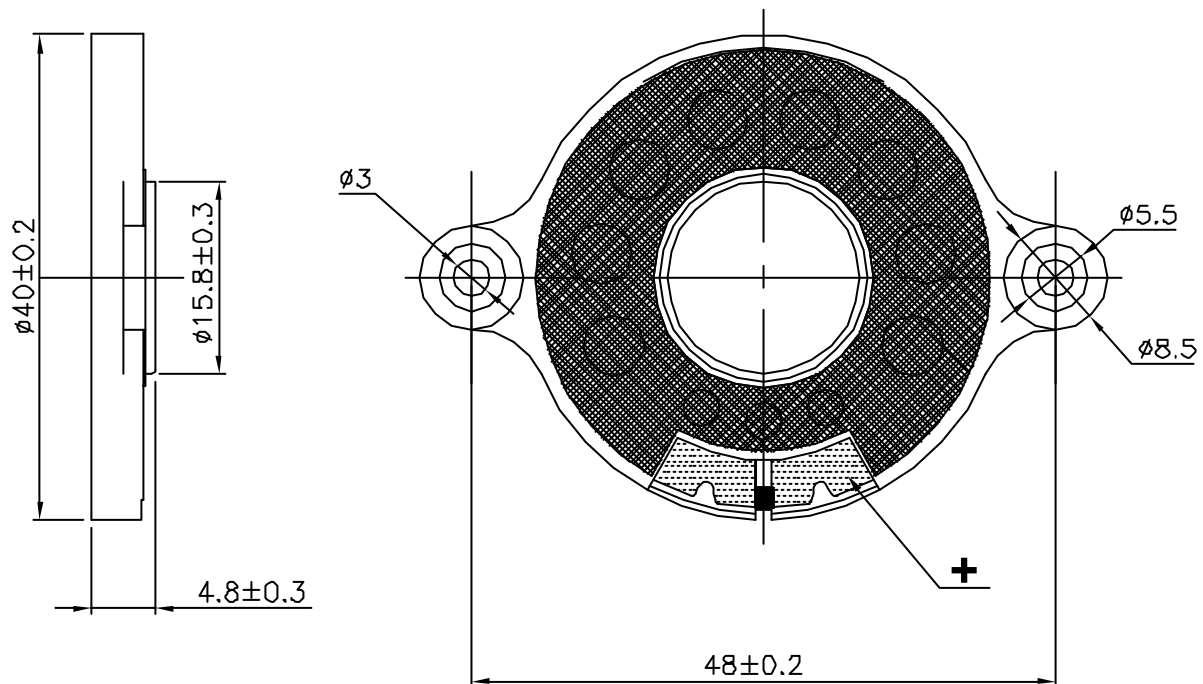

Unit : mm

Housing Material : METAL

40DS08GE-1-M75ND VOL:2.0V(0.5W) DIS:0.5M VANSONIC
X:1.0000kHz *Y:86.45dB ZA:1.0000 SSR Fund.

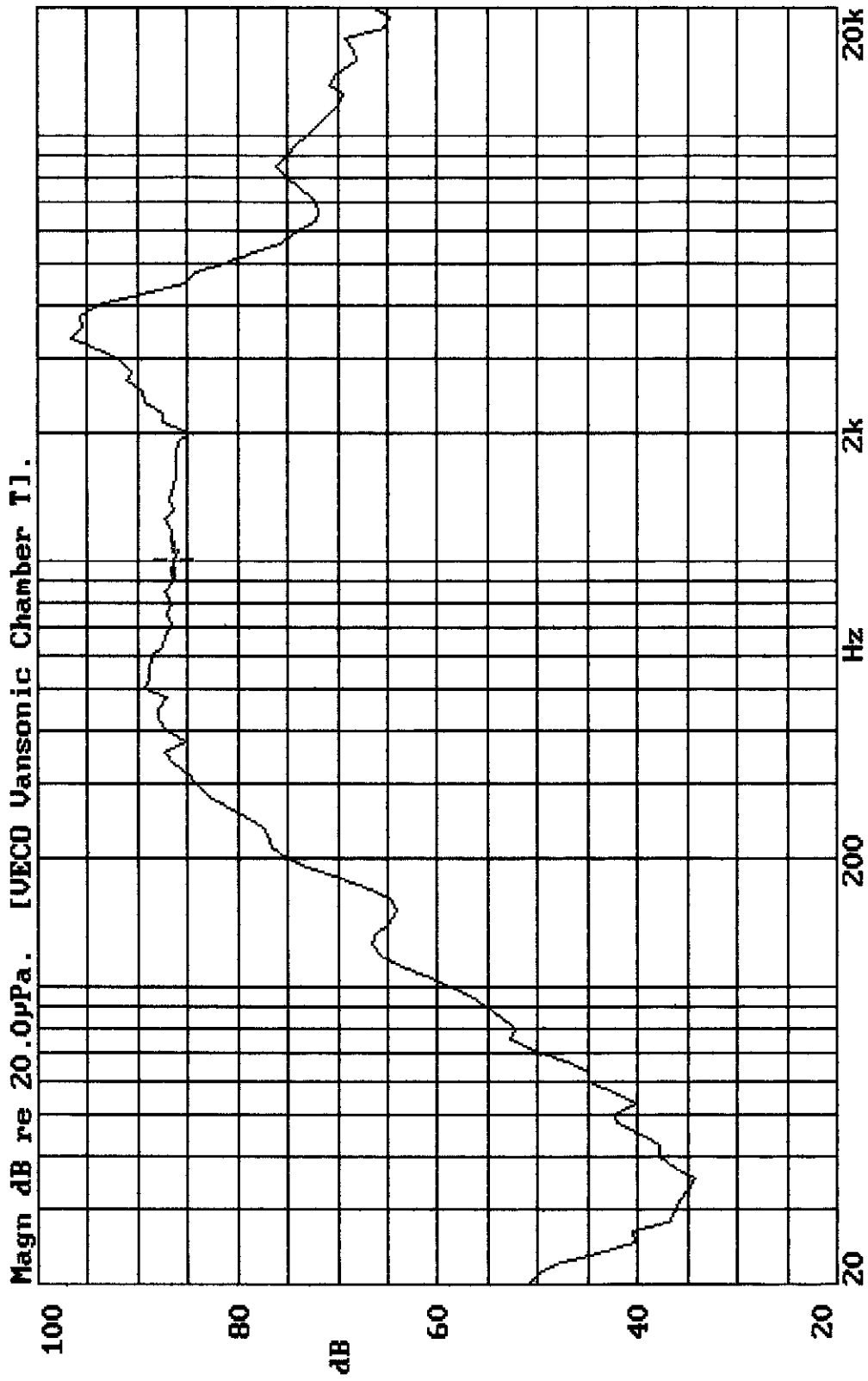

11-AUG-2000 16:19:21

Mode: SSR

