

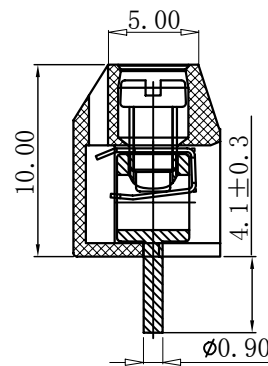

ULO GROUP
INSPIRING CONNECTIONS

NINGBO ULO ELECTRONICS CO LTD

product specification

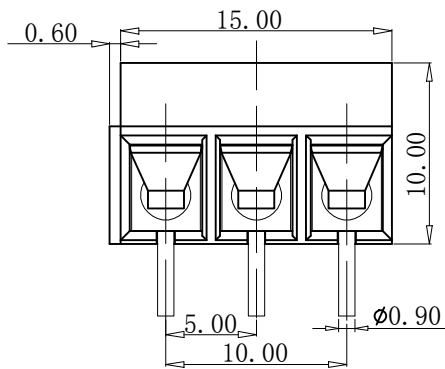
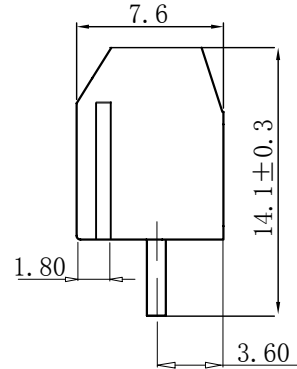
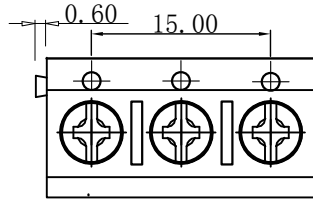

Electrical

Standard: UL IEC/TUV
 Rated voltage: 300V 250V
 Rated current: 20A 17.5A
 Contact resistance: 20 mΩ
 Wire range: 26-14AWG max.1.5mm²
 Withstanding voltage: AC2000V/Min
 Insulation resistance: 500mΩ/DC500V

Mechanical

Temp Range: -40°C~+105°C
 Torque: 0.4Nm(3.5lb 'in)
 Strip length: 5-6mm

Dimensions

Pitch: 5.0mm
 Poles: 3P

Material

Housing: PA66,UL94V-0
 Screws:M2.5,steel.Zinc plated
 Pin header: B Brass,TiN plated
 Shrapnel:Stainless steel

HOW TO ORDER **ULO-TB** 2 5 - 301/5.0 - 0 3 P - 6 - 1 - 0 - 0 B

Certificate Series No.

Factory Code

Poles

0:Slot Screw
1:Cross Screw

Cage Type
0A:Thick brass
0B:Normal brass
0C:Steel

0: Screw Down
1: Screw Up

Grey	1	Green	4	Transparent	7
Blue	2	Orange	5	Yellow	8
Black	3	Red	6	White	9

TOLERANCES EXCEPT AS NOTED

		linear dimension(Tolerances Standard GB/T 14486-2008)										≡	—	□	//	⊥	
variable range	to	over 6 to 6	over 10 to 10	over 18 to 18	over 30 to 30	over 50 to 50	over 80 to 80	over 120 to 120	over 160 to 160	over 200 to 200	over 250 to 250	all	to 5	over 5 to 30	over 30 to 120	over 120 to	
	tolerance		+0.1	+0.14	+0.19	+0.25	+0.32	+0.43	+0.57	+0.72	+0.88	+1.05	+1.25	0.5	0.025	0.06	0.12

UNITS	mm	SIZE	A4	SCALE	THIRD ANGLE PROJECTION	
NINGBO ULO ELECTRONICS CO LTD						
					NAME	ULO-TB25-301/5.0