



## Introducing Solderless LED Socket, Type CM

Tyco Electronics' Solderless LED Socket, Type CM provides a solderless quick termination to the 1500 lumen output Cree XLamp® MP-L™ LED. This solderless termination technique facilitates easy integration of the LED into the end customer's lighting fixtures with simple screw-down installation. Multiple versions are offered to provide application flexibility. To further enhance functionality to the fixture manufacturer, the socket also features integral, robust, snap attachment of LEDIL Tyra series reflector optics.

### KEY FEATURES

- Solderless termination to the Cree XLamp MP-L LED
- Fast, rapid termination and assembly
  - eliminates hand soldering wires to the MPL 0.70mm x 0.85mm pads
- Offered in separable board termination and wire termination versions
- Snap-on optics assembly using LEDIL's Tyra series reflector optics

### APPLICATIONS

- Commercial and residential Lighting Fixtures
- Integrated custom lighting

# Solderless LED Socket, Type CM

## LIGHTING APPLICATIONS



Channel/Sign



Emergency



Digital Signage



Architectural



Street & Stadium



Indoor



Office



Commercial Refrigeration

## ELECTRICAL

Operating current: 500mA

Operating voltage: 30VDC

Dielectric withstanding voltage: 500 VDC

## MECHANICAL

Select silver plated contact interface to Cree XLamp MP-L LED

6 line termination in both wire and board termination versions

Secure attachment to substrate using three standard #4 or M3 screws

Wire version incorporates 6 position AMP Mini CT header

Low profile- <3 mm height around the dome (w/o latches) and 5.20 mm high at the connector interface

## MATERIALS

Housings: 94 V0 rated high temperature resistant thermoplastic

Contacts:

- Base material copper alloy
- Silver plated interface to Cree XLamp MP-L LED
- Tin plated interface to AMP Mini CT or to PCB

## APPLICATIONS AND SPECIFICATION

Product Specification 108-2439

Application specification 114-13281

# Solderless LED Socket, Type CM

## PRODUCT OFFERINGS

PART NUMBER	DESCRIPTION
<b>2106946-1</b>	LED to Wire, w/o Optics Latch
<b>2106946-2</b>	LED to Wire, w/ Optics Latch
<b>2106946-3</b>	LED to Board, w/o Optics Latch
<b>2106946-4</b>	LED to Board, w/ Optics Latch
<b>2106946-5</b>	LED to Inverted Wire, w/o Optics Latch
<b>2106946-6</b>	LED to Inverted Wire, w/ Optics Latch
<b>2058943-5</b>	AMP Mini CT, 6 position Cable Assembly

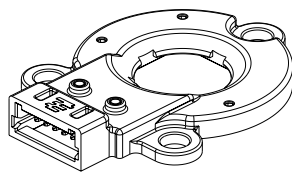

**2106946-1**

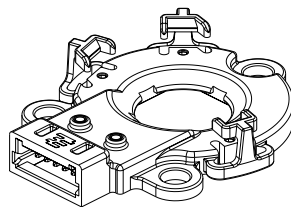

**2106946-2**

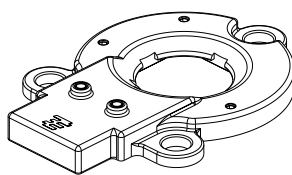

**2106946-3**

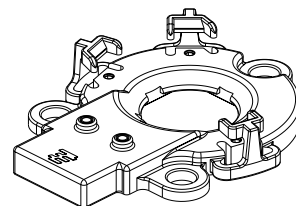

**2106946-4**

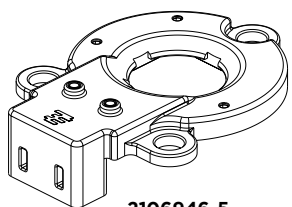

**2106946-5**

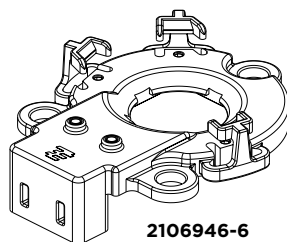

**2106946-6**

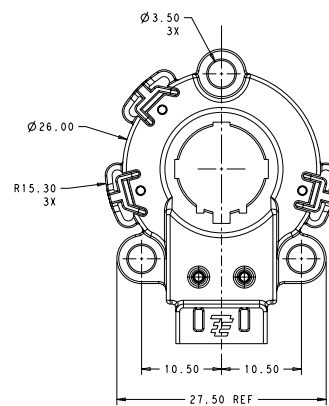

**2106946-2**

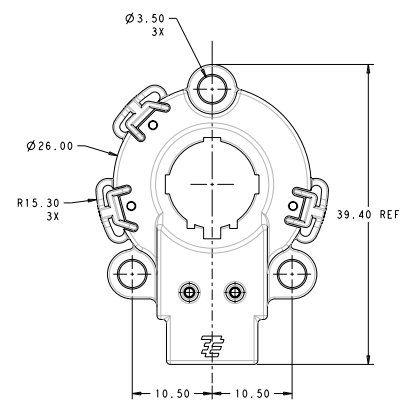

**2106946-4**

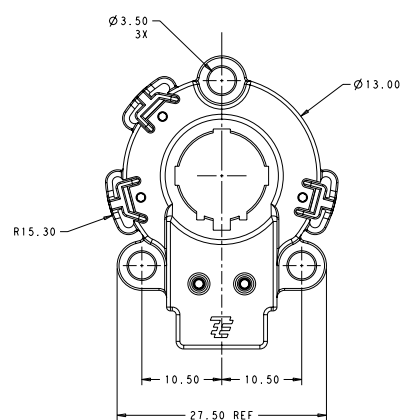

**2106946-6**

# Questions to ask at design in

## Is the customer looking at or is the customer using the Cree XLamp MP-L LED? If yes, what is the application and how is the customer terminating to the pads on the top of the Cree XLamp MP-L LED?

The Solderless LED Socket Type CM offers a solderless termination to the pads on the top of the socket and offers an ideal alternative to hand soldering wires onto very small pads spaced on 1.25 mm centerlines.

### How do I decide which socket to use?

This is entirely dependent on the customer's application. In such instances where the Cree XLamp MP-L LED is mounted to a circuit board, it often makes sense for the customer to also mount driver circuitry onto the same circuit board. The board mount socket can then be used to connect the Cree XLamp MP-L LED to the PCB and thereby to the driver circuitry on the board. Another remote connector (AMP Mini CT, micro MATE-N-LOK, HPI connectors or the like) is then used to provide power to the board.

The Cree XLamp MP-L LED can also be thermally epoxied directly to a heat sink. If this is the avenue the customer is using, then one of the wire mount versions is best. The inverted wire version can be used where the customer has the option to allow for connector access within the heat sink and offers the most compact installation option. In instances where the customer has room or can not provide connector access within the heat sink, the horizontal wire mount is used since it allows easy access to the connection from the LED side of the assembly.

## The Cree XLamp MP-L LED employs three parallel strings of LEDs and therefore requires three circuits hence the need for 6 connections. Each LED circuit is nominally 25VDC at 150mA which is well within the 50VDC voltage rating of the AMP Mini CT connector. Can the customer serially connect the three strings at 75VDC rather than run them in parallel?

This is not recommended since the resulting 75VDC drop across the LED exceeds the 50VDC rating of the AMP Mini CT connector.

### Is special application tooling required?

Not typically although when thermally epoxying the Cree XLamp MP-L LED directly to the heat sink, a fixture is recommended to ensure the LED is properly located to the socket mounting holes in the heat sink.

## Do I need to epoxy the Cree XLamp MP-L LED to the heat sink or can I just use thermal grease or solid thermal pad as the interface material?

TE does not recommend thermal grease or thermal pads with the SolderlessLED Socket, Type CM as the socket is not designed to provide the normal force to the grease/pad required for optimal thermal performance.

**FOR MORE INFORMATION :** [www.tycoelectronics.com/lighting](http://www.tycoelectronics.com/lighting)

### Technical Support

Internet:	<a href="http://www.tycoelectronics.com/help">www.tycoelectronics.com/help</a>
USA:	+1 (800) 522-6752
Canada:	+1 (905) 470-4425
Mexico & Central America:	+52(0) 55-1106-0814
South America:	+55 (0) 11-2103-6000
Germany:	+49 (0) 6251-133-1999
UK:	+44 (0) 800-267666
France:	+33 (0) 1-3420-8686
Netherlands:	+31 (0) 73-6246-999
China:	+86 (0) 400-820-6015

Part numbers in this brochure are RoHS Compliant\*, unless marked otherwise.

\*as defined [www.tycoelectronics.com/leadfree](http://www.tycoelectronics.com/leadfree)

### Tyco Electronics Corporation

Harrisburg, PA

### [tycoelectronics.com](http://tycoelectronics.com)

© 2010 Tyco Electronics Corporation All Rights Reserved.

5-1773457-1 3M MS FP 05/2010

AMP, MATE-N-LOK, TE (logo) and Tyco Electronics are trademarks of the Tyco Electronics group of companies and its licensors.

Other products, logos, and Company names mentioned herein may be trademarks of their respective owners.

Cree and XLamp are registrations and MP-L is a trademark of Cree, Inc.

While Tyco Electronics has made every reasonable effort to ensure the accuracy of the information in this catalog, Tyco Electronics does not guarantee that it is error-free, nor does Tyco Electronics make any other representation, warranty or guarantee that the information is accurate, correct, reliable or current. Tyco Electronics reserves the right to make any adjustments to the information contained herein at any time without notice. Tyco Electronics expressly disclaims all implied warranties regarding the information contained herein, including, but not limited to, any implied warranties of merchantability or fitness for a particular purpose. The dimensions in this catalog are for reference purposes only and are subject to change without notice. Specifications are subject to change without notice. Consult Tyco Electronics for the latest dimensions and design specifications.