

SPECIFICATION

Customer :

Customer P/N :

Product description : Magnetic Transducer

CFDT036

.

Compliance with ROHS

Signature of Approval

--

Approved by	Checked by	Issued by	Date

Specification for Magnetic Transducer	Page	2/10
Model No. : CFDT036	Revision No.	1.0
	Drawing No.	

CONTENTS

1. Scope
2. General
3. Electrical and Acoustic Characteristics.
4. Reliability Test
5. Measurement Block Diagram & Response curve
6. Structure
7. Dimensions
8. Packing
9. Revision

Specification for Magnetic Transducer		Page	3/10
Model No. : CFDT036		Revision No.	1.0
		Drawing No.	

1. Scope

This product specification is applied to the magnetic transducer in alarm systems. Please contact us when using this product for any other applications than described in the above.

2. General

2.1 Out-Diameter : 8.5X8.5mm

2.2 Height : 4.0 mm

2.3 Weight : 0.4 g

2.4 Operating Temperature range:
-40~+80 °C without loss of function

2.5 Store Temperature range:
-40 ~ +80°C without loss of function

3. Electrical and Acoustic Characteristics.

Test condition : 15 ~ 35 °C , 25% ~ 85% RH, 860~1060 mbar

	Items	Specification
1	Rated Voltage	3.6V
2	Operating Voltage	2.0~4.0V
3	Max. Rated Current	80mA /3.6V
4	Resonant Frequency	2670Hz
5	Min. Sound Pressure Level	87dB/3.6V/10cm
6	Coil Resistance	16± 3 Ω
7	Coil Impedance	40 Ω
8	Case Material/Color	PPS/Black

Specification for Magnetic Transducer		Page	4/10
Model No. : CFDT036		Revision No.	1.0
		Drawing No.	

4. Reliability Test

After test(1~7item), the transducer S.P.L . difference shall be within $\pm 10\text{dB}$, and the appearance not exist any change to be harmful to normal operation(e.g.cracks,rusts,damages and especially distortion).

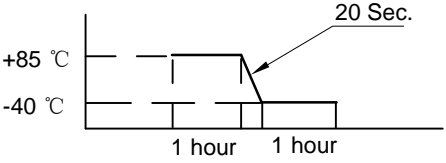
	Item	Specification
1	High Temperature Test	After being worked in a chamber with $+85\pm 2\text{ }^\circ\text{C}$ for 2h and then being placed in natural condition for 2h, sounder shall be measured.
2	Low Temperature Test	First being worked in a chamber with $-40\pm 2\text{ }^\circ\text{C}$ for 2h and then being placed in a chamber with $-40\pm 2\text{ }^\circ\text{C}$ for 16h, finally being placed in natural condition for 2h, sounder shall be measured.
3	Humidity Test	After being placed in a chamber with 90 to 95%R.H. at $+40\pm 2\text{ }^\circ\text{C}$ for 2 h and then being placed in natural condition for 2h , sounder shall be measured.
4	Thermal Shock Test	<p>After being worked in a chamber at $+85\text{ }^\circ\text{C}$ for 1 hour, then sounder shall be placed in a chamber at $-40\text{ }^\circ\text{C}$ for 1 hour(1 cycle is the below diagram).</p> <p>After 6 above cycles, sounder shall be measured after being placed in natural condition for 1 hour.</p> 

Specification for Magnetic Transducer		Page	5/10
Model No. : CFDT036		Revision No.	1.0
		Drawing No.	

4. Reliability Test

	Item	Specification
5	Vibration Resistance	Sounder shall be measured after being applied vibration of amplitude of 1.5mm with 10 to 30Hz band of vibration frequency to each of 3 perpendicular directions for 2 hour.
6	Drop Test	Sounder packed in the carton are dropped in six direction from the height of 80cm to the concrete floor.
7	Solderability	Lead terminals are immersed in rosin for 5 seconds and then immersed in solder bath of $+260 \pm 5^{\circ}$ C for 3 ± 0.5 seconds.
8	Terminal Strength Pulling	The force 10 seconds of 9.8N is applied to each terminal in axial direction.

Specification for Magnetic Transducer		Page	6/10
Model No. : CFDT036		Revision No.	1.0
		Drawing No.	

5. Measurement Block Diagram & Response curve

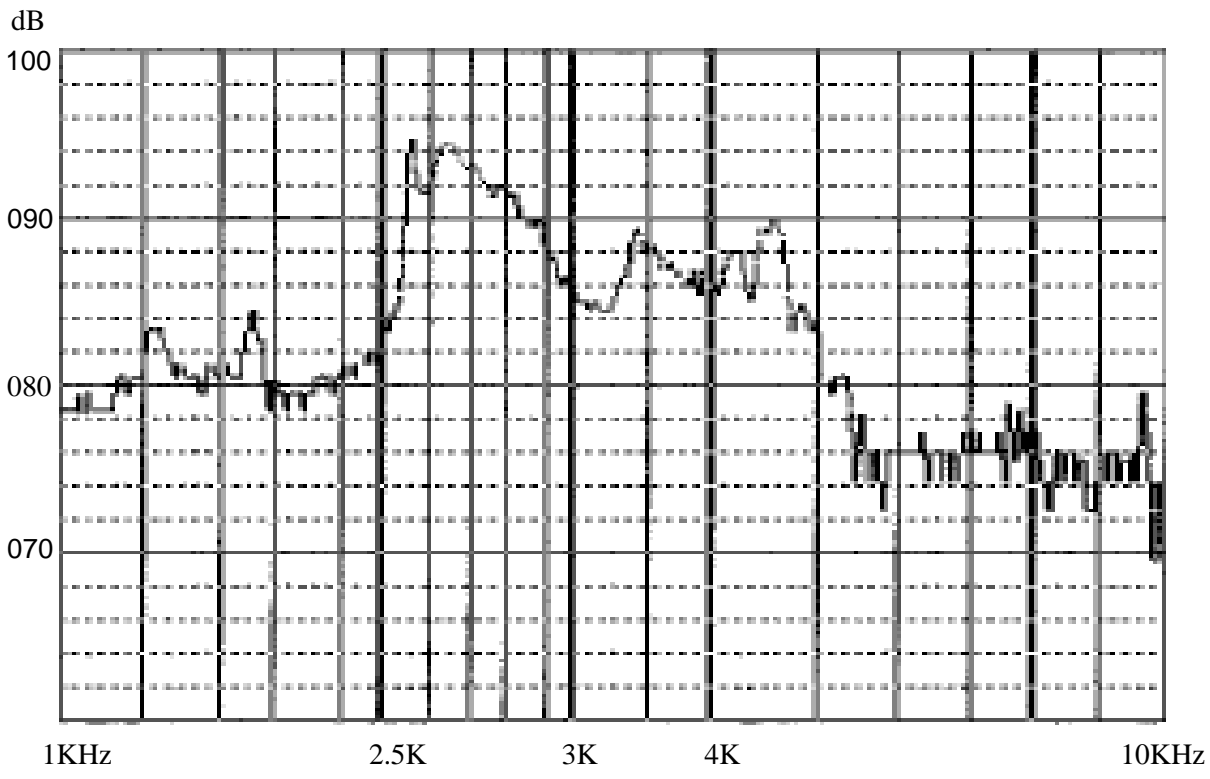
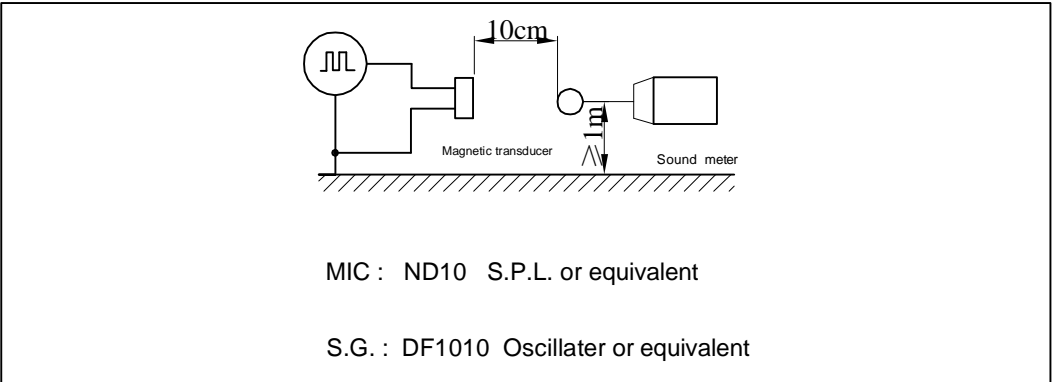
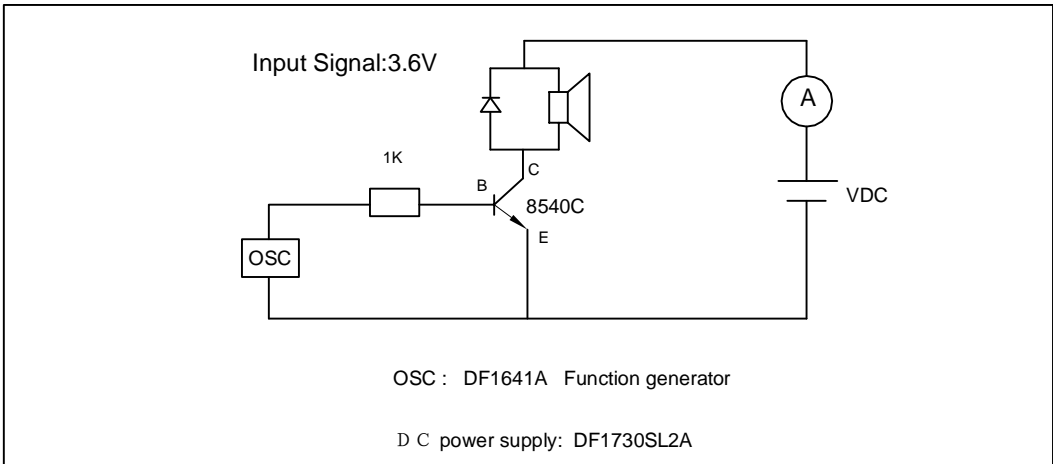

Specification for Magnetic Transducer		Page	7/10
		Revision No.	1.0
Model No. : CFDT036		Drawing No.	

6. Structure

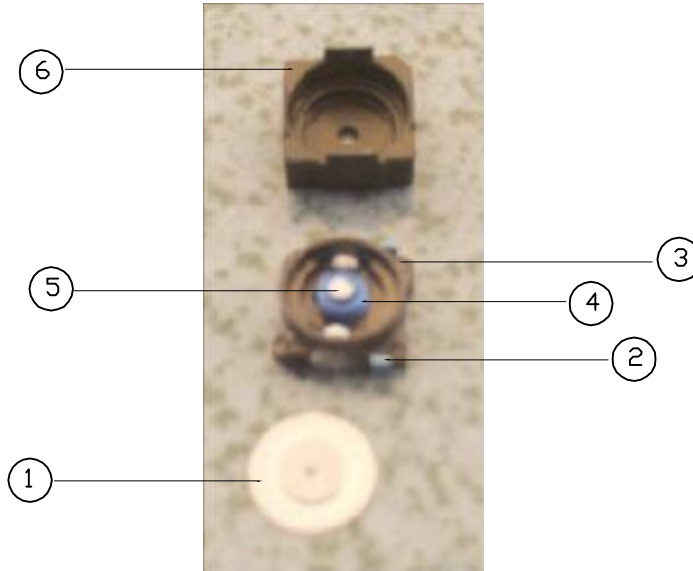

6	Case	1	PPS	SH534731/CHEM (A)
5	T Core	1	Fe	SH415361/CHEM(D)
4	Coil	1	QANR	SH437207/CHEM(NO.2)
3	Magnetic ring	1	/	2083631/LD(1)
2	PCB with pin	1	/	SH543760/CHEM (A) CH411778-1/CHEM(A)
1	Diaphragm	1	/	SH415361/CHEM (A/B)
No.	Part Name	Q'TY	Material	GSG

Specification for Magnetic Transducer	Page	8/10
	Revision No.	1.0
Model No. : CFDT036	Drawing No.	

7. Dimensions

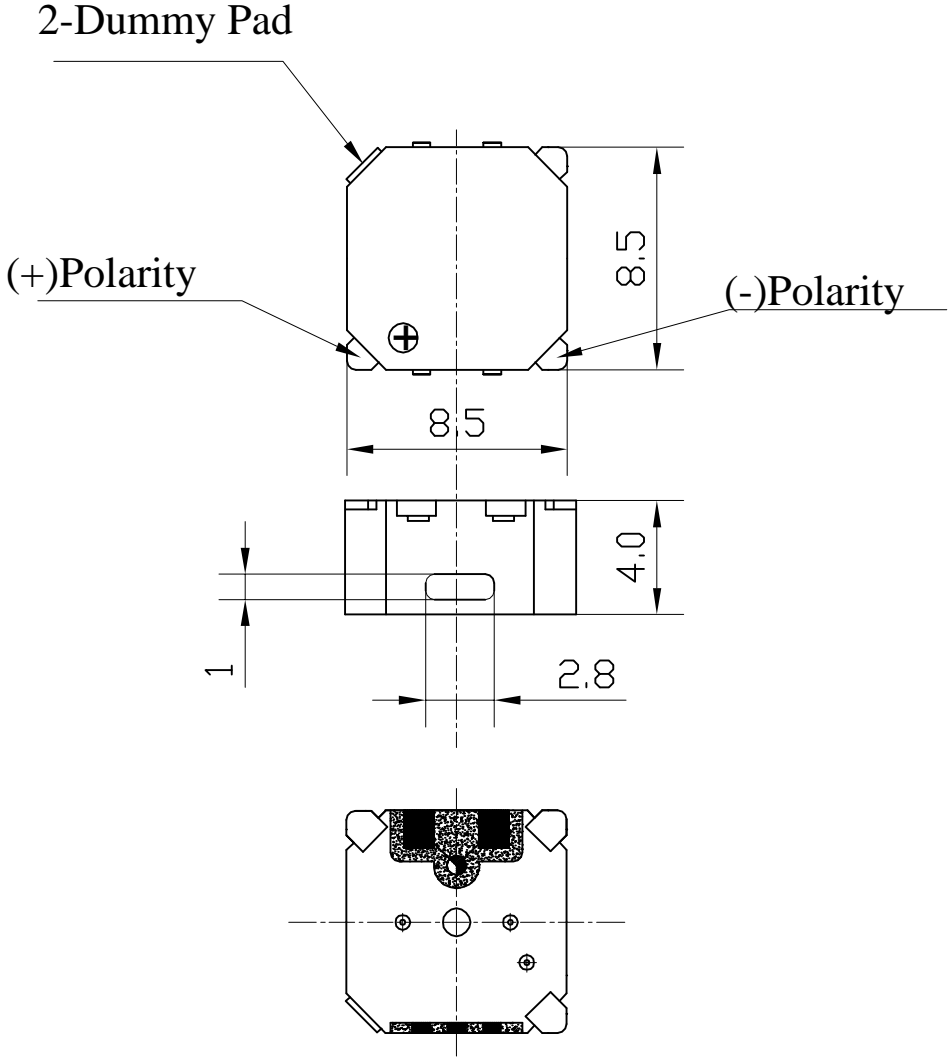

FIRST ANGLE PROJECTION

UNIT : mm
Tolerance : ±0.5

Specification for Magnetic Transducer	Page	9/10
	Revision No.	1.0
	Drawing No.	
Model No. : CFDT036		

8. Packing

TRAY
1,000PCS

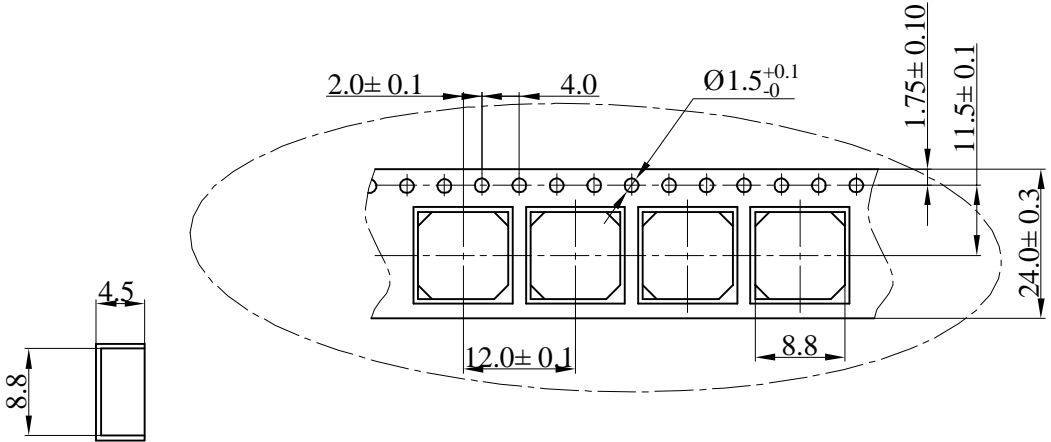

INNER BOX
:TRAY 1PCS
TOTAL 1,000PCS

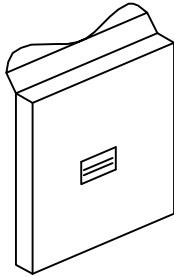

INNER BOX
337X337X28mm

CARTON BOX
:INNER BOX 5PCS
TOTAL 5000PCS

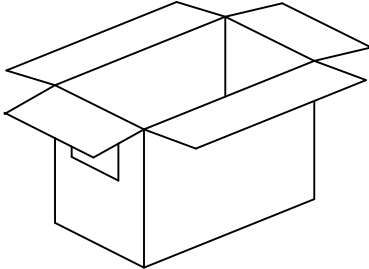

CARTON BOX
345X170X345