

1.0 Features

- Primary-side feedback eliminates opto-isolators and simplifies design
- No-load power consumption < 20 mW at 230 V_{ac} with typical application circuit (5 star rating)
- Active start-up scheme enables fastest possible start-up
- Fast dynamic load response
- Adaptive multi-mode PWM/PFM control improves efficiency
- Quasi-resonant operation for highest overall efficiency
- EZ-EMI[®] design to easily meet global EMI standards
- Direct drive of low-cost BJT switch
- Dynamic base current control
- Very tight constant voltage and constant current regulation with primary-side-only feedback
- No external compensation components required
- Complies with EPA 2.0 energy-efficiency specifications with ample margin
- Ultra-low start-up current (1.5 μA typical)
- Built-in soft start
- Built-in short circuit protection and output overvoltage protection
- Built-in current sense resistor short circuit protection
- No audible noise over entire operating range

2.0 Description

The iW1697 is a high performance AC/DC power supply controller which uses digital control technology to build peak current mode PWM flyback power supplies. The device together with an external active device (depletion mode NFET or NPN BJT) provides a fast start-up without compromising no-load power loss. The device directly drives a power BJT and operates in quasi-resonant mode to provide high efficiency along with a number of key built-in protection features while minimizing the external component count, simplifying EMI design and lowering the total bill of material cost. The iW1697 removes the need for secondary feedback circuitry while achieving excellent line and load regulation. It also eliminates the need for loop compensation components while maintaining stability over all operating conditions. Pulse-by-pulse waveform analysis allows for a loop response that is much faster than traditional solutions, resulting in improved dynamic load response. The built-in power limit function enables optimized transformer design in universal off-line applications and allows for a wide input voltage range.

iWatt's innovative proprietary technology ensures that power supplies built with iW1697 can achieve both highest average efficiency and less than 20 mW no-load power consumption, and have fast dynamic load response, all with a typical application circuit. The active start-up scheme enables shortest possible start-up time without sacrificing no-load power loss.

3.0 Applications

- Low power AC/DC adapter/chargers for cell phones, PDAs, digital still cameras
- Linear AC/DC replacement

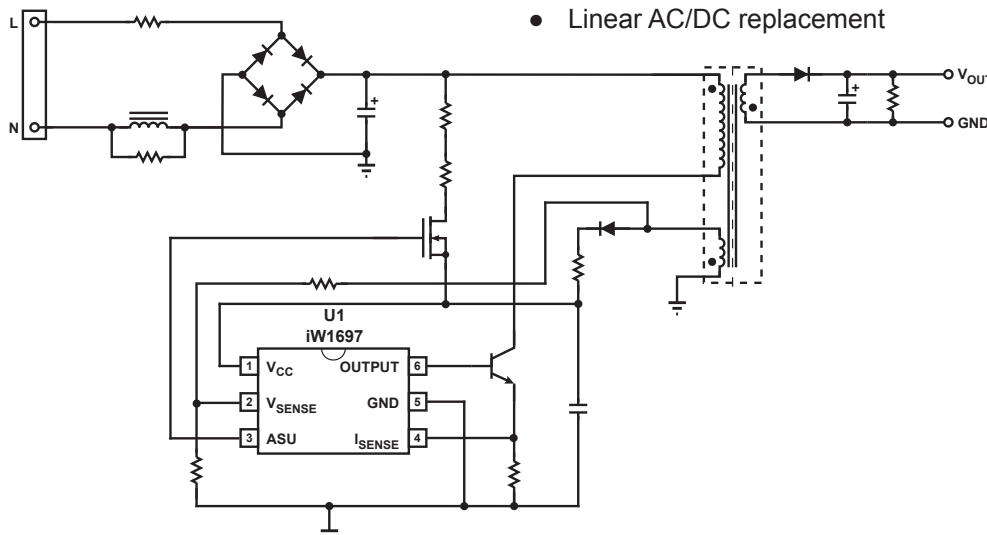

Figure 3.1: iW1697 Typical Application Circuit

(Achieving < 20 mW No-load Power Consumption. Using Depletion Mode NFET as the Active Start-up Device)

iW1697 Product Brief

Low-Power Off-Line Digital Green-Mode PWM Controller

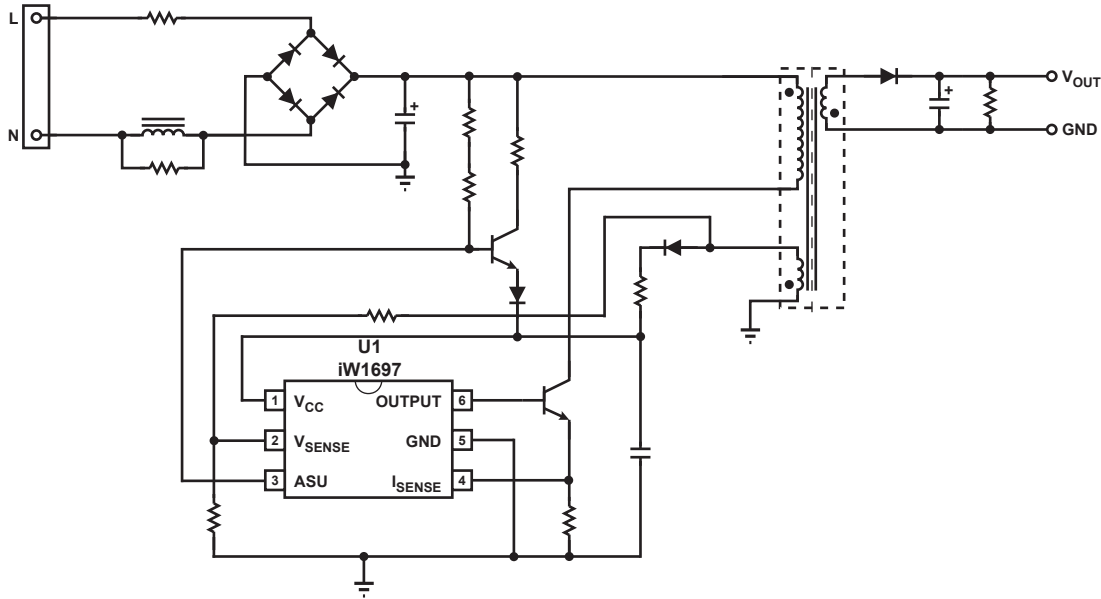

Figure 3.2: iW1697 Typical Application Circuit

(Achieving < 20 mW No-load Power Consumption. Using NPN BJT as the Active Start-up Device)

4.0 Pinout Description

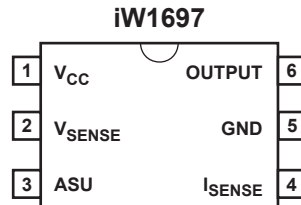

Figure 4.1: 6 Lead SOT-23 Package

Pin #	Name	Type	Pin Description
1	V _{CC}	Power Input	Power supply for control logic.
2	V _{SENSE}	Analog Input	Auxiliary voltage sense (used for primary regulation).
3	ASU	Output	Control signal for active start-up device (BJT or depletion NFET).
4	I _{SENSE}	Analog Input	Primary current sense. Used for cycle-by-cycle peak current control and limit.
5	GND	Ground	Ground.
6	OUTPUT	Output	Base drive for BJT.

5.0 Absolute Maximum Ratings

Absolute maximum ratings are the parameter values or ranges which can cause permanent damage if exceeded.

Parameter	Symbol	Value	Units
DC supply voltage range (pin 1, $I_{CC} = 20\text{mA max}$)	V_{CC}	-0.3 to 18	V
Continuous DC supply current at V_{CC} pin ($V_{CC} = 15\text{ V}$)	I_{CC}	20	mA
ASU output (pin 3)		-0.3 to 18	V
Output (pin 6)		-0.3 to 4.0	V
V_{SENSE} input (pin 2, $I_{Vsense} \leq 10\text{ mA}$)		-0.7 to 4.0	V
I_{SENSE} input (pin 4)		-0.3 to 4.0	V
Maximum junction temperature	$T_{J\text{ MAX}}$	125	°C
Storage temperature	T_{STG}	-65 to 150	°C
Lead temperature during IR reflow for ≤ 15 seconds	T_{LEAD}	260	°C
Thermal resistance junction-to-ambient	θ_{JA}	190	°C/W
ESD rating per JEDEC JESD22-A114		2,000	V
Latch-up test per JEDEC 78		± 100	mA

iW1697 Product Brief

Low-Power Off-Line Digital Green-Mode PWM Controller



6.0 Physical Dimensions

6-Lead SOT Package

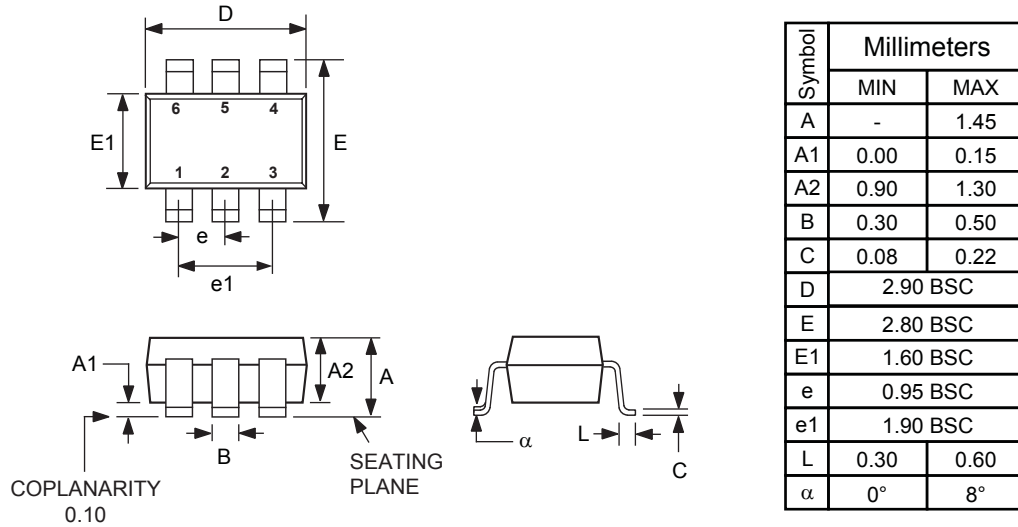

Figure 6.1 : Physical dimensions, 6-lead SOT-23 package

Compliant to JEDEC Standard MO-178AB

Controlling dimensions are in millimeters

This package is RoHS compliant and Halide free.

Soldering Temperature Resistance:

[a] Package is IPC/JEDEC Std 020D Moisture Sensitivity Level 1

[b] Package exceeds JEDEC Std No. 22-A111 for Solder Immersion Resistance; packages can withstand 10 s immersion < 270°C

Dimension D does not include mold flash, protrusions or gate burrs. Mold flash, protrusions or gate burrs shall not exceed 0.25 mm per side. D and E1 dimensions are determined at datum H.

The package top may be smaller than the package bottom. Dimensions D and E1 are determined at the outermost extremes of the plastic body exclusive of mold flash, tie bar burrs and interlead flash, but including any mismatch between top and bottom of the plastic body. D and E1 dimensions are determined at datum H.

7.0 Ordering Information

Part Number	Options	Package	Description
iW1697-00	Cable Comp = 0 mV	SOT-23	Tape & Reel ¹
iW1697-01	Cable Comp = 300 mV	SOT-23	Tape & Reel ¹
iW1697-03	Cable Comp = 450 mV	SOT-23	Tape & Reel ¹
iW1697-05	Cable Comp = 150 mV	SOT-23	Tape & Reel ¹

Note 1: Tape & Reel packing quantity is 3,000 per reel. Minimum ordering quantity is 3,000.

iW1697 Product Brief

Low-Power Off-Line Digital Green-Mode PWM Controller



About iWatt

iWatt Inc. is a fabless semiconductor company that develops intelligent power management ICs for computer, communication, and consumer markets. The company's patented *pulseTrain*[™] technology, the industry's first truly digital approach to power system regulation, is revolutionizing power supply design.

Trademark Information

© 2009 iWatt, Inc. All rights reserved. iWatt, the iW light bulb, *EZ-EMI* and *pulseTrain* are trademarks of iWatt, Inc. All other trademarks and registered trademarks are the property of their respective companies.

Contact Information

Web: <http://www.iwatt.com>

E-mail: info@iwatt.com

Phone: 408-374-4200

Fax: 408-341-0455

iWatt Inc.

101 Albright Way

Los Gatos CA 95032-1827

Disclaimer

iWatt reserves the right to make changes to its products and to discontinue products without notice. The applications information, schematic diagrams, and other reference information included herein is provided as a design aid only and are therefore provided as-is. iWatt makes no warranties with respect to this information and disclaims any implied warranties of merchantability or non-infringement of third-party intellectual property rights.

Certain applications using semiconductor products may involve potential risks of death, personal injury, or severe property or environmental damage ("Critical Applications").

IWATT SEMICONDUCTOR PRODUCTS ARE NOT DESIGNED, INTENDED, AUTHORIZED, OR WARRANTED TO BE SUITABLE FOR USE IN LIFE-SUPPORT APPLICATIONS, DEVICES OR SYSTEMS, OR OTHER CRITICAL APPLICATIONS.

Inclusion of iWatt products in critical applications is understood to be fully at the risk of the customer. Questions concerning potential risk applications should be directed to iWatt, Inc.

iWatt semiconductors are typically used in power supplies in which high voltages are present during operation. High-voltage safety precautions should be observed in design and operation to minimize the chance of injury.