

# GOT3106T-832

10.4" SVGA TFT Extended Temp. Fanless Touch Panel Computer with Intel® Atom™ Processor N2600 (-20°C +55°C)

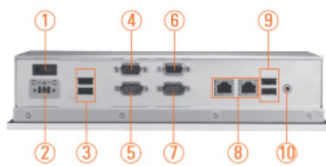

- |                                    |                         |
|------------------------------------|-------------------------|
| 1. Power switch (ATX)              | 6. VGA                  |
| 2. Power input connector (phoenix) | 7. COM 2 (RS-232)       |
| 3. 2 x USB 2.0                     | 8. 2 x Ethernet (RJ-45) |
| 4. COM 3 (RS-232)                  | 9. 2 x USB 2.0          |
| 5. COM 1 (RS-232/422/485)          | 10. Audio (Line-out)    |



## Introduction

The GOT3106T-832 is the 10.4" fanless touch panel computer. By supporting a wide temperature range from -20°C to +55°C, the panel system is especially designed for harsh environments. It adopts a modern, super sleek fanless design, is equipped with a 10.4" TFT LCD, and low power consumption Intel® processor. In response to customer's requests for wireless applications, the GOT3106T-832 has a Mini card slot and an optional fixed rotational WLAN antenna for wireless network connection. By just plugging in the Mini card WLAN card, customers have instant access wireless LAN. The GOT3106T-832 is used extensively for variety of industry needs including transportation, packing field surveillance, building automation, and more.

### Wide-temperature (-20°C ~ +55°C) supported

The 10.4 touch panel PC adopts unique extended temperature technology, with a temperature range from -20°C to +55°C, a fanless cooling system and compact design for harsh environments.

### WLAN antenna supported (optional)

The industrial panel PC provides a Mini card slot and an optional fixed rotational WLAN antenna for wireless network connections. By simply plugging in the wireless LAN card, customers can use the unit in a wireless environment.

### Anti-vibration up to 1.3G

With a special vibration-resistant design patent, 10.4-inch GOT3106T-832 can work well under 1.3G (10-500Hz) in operation mode, and equipped with a 2.5" HDD.

## Features

- 10.4" SVGA (800 x 600) color TFT LCD
- Fanless cooling system with Intel® Atom™ N2600 1.6 GHz
- Supports wide temperature range of -20°C ~ +55°C
- Anti-vibration up to 1.3G (HDD, random)
- Supports WLAN antenna
- Over-current power protection-fuse
- Supports panel mount, wall mount, VESA arm, desktop stand (optional)



▲ Side view



▲ Rear view

## Specifications

Front Bezel	IP65, NEMA 4 rugged protection, aluminum front bezel		
LCD Panel	Display Type	10.4" SVGA TFT LCD	
	Brightness (cd/m <sup>2</sup> )	400 nits	
	Resolution	800 x 600	
Main System	CPU	Intel® Atom™ processor N2600 1.6 GHz	
	Chipset	Intel® NM10 Express	
	System Memory	1 x 204-pin DDR3 SO-DIMM max. up to 2 GB	
	BIOS	AMI UEFI BIOS	
	Storage	1 x 2.5" SATA HDD	
		1 x CompactFlash™	
	Watchdog Timer	255 levels, 0-255 sec.	
	Onboard Graphics	Integrated in Intel® GFX	

## Specifications

I/O Connector	2 x RS-232 (COM 2/3) 1 x RS-232/422/485 (COM 1) 1 x VGA 1 x Audio (Line-out) 4 x USB 2.0 2 x 10/100/1000Mbps Ethernet
Expansion Interface	1 x PCIe Mini Card
Touchscreen	Resistive type
Power Supply	10~30VDC with power protection
Dimensions	223.55 mm (8.76") x 63.09 mm (2.47") x 277 mm (10.86")
Packing Dimensions	380 mm (14.9") x 190 mm (7.45") x 440 mm (17.25")
Weight (net/gross)	2.4 kg (5.29 lb)/ 3.8 kg (8.38 lb)
Environment	Operating temperature: -20°C ~ +55°C (-4°F ~ +131°F) (with W.T. DRAM/HDD/CF) Storage Temperature: -30°C ~ +80°C (-22°F ~ +176°F) Relative humidity: 20% ~ 90% @ 40°C; non-condensing Operation vibration: 1.3G, 10 ~ 500Hz, random for 2.5" HDD 2G, 10 ~ 500Hz, random for CompactFlash™
Certificate	CE

\* W.T.: Wide Temperature. All W.T. supported products have to be sorted by Axiomtek.

## Ordering Information

GOT3106T-832	10.4" SVGA TFT fanless touch panel computer with Intel® Atom™ N2600 (-20°C ~ +55°C)
--------------	---

\* Specification and certifications are based on options and may vary.

## Optional EOS Installation

WES
Windows® 7 Embedded (32-bit)

## Optional OS Installation

Windows® XP
Windows® 7 (32-bit)

## Dimensions

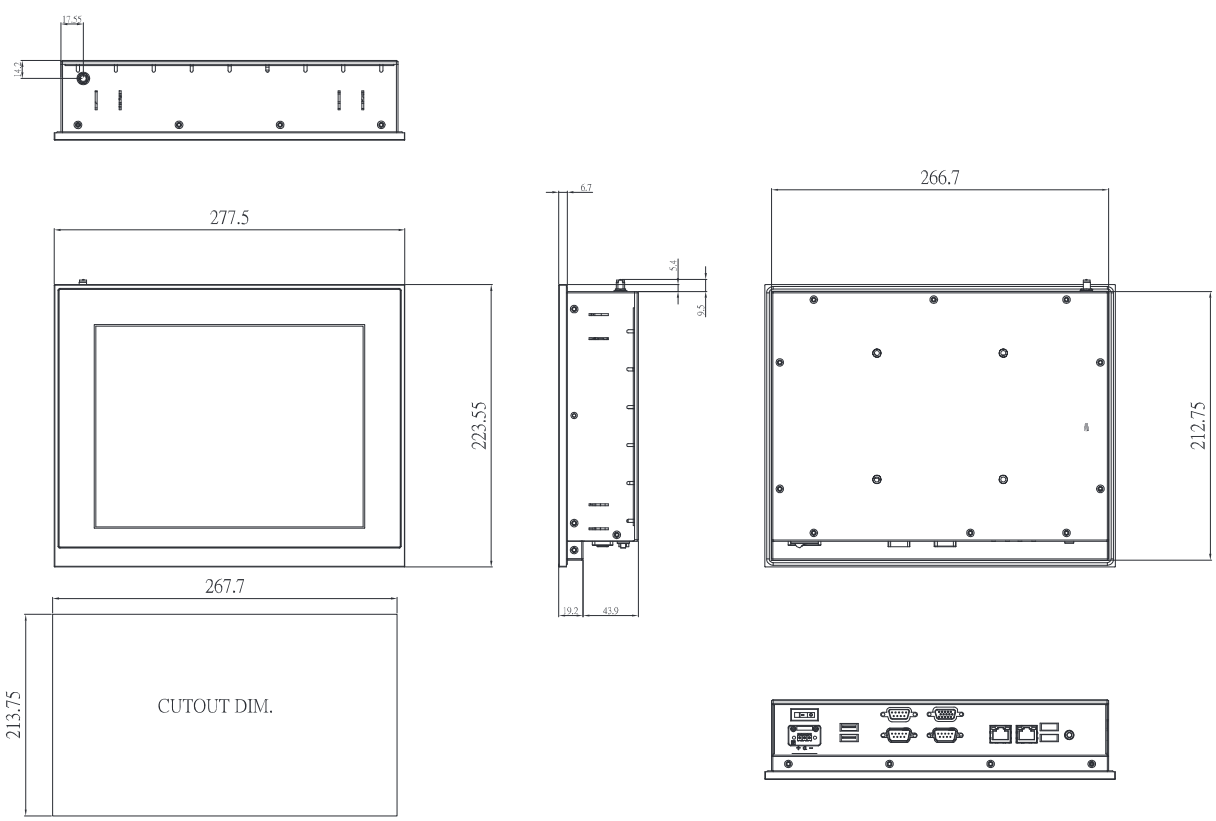

\* All specifications and photos are subject to change without notice.