



Approved by:
Checked by:
Issued by:

# **SPECIFICATION**

**MODEL: SJK-6T3-19.680-2.0-G**

**深圳市晶科鑫实业有限公司**  
**SHENZHEN CRYSTAL TECHNOLOGY INDUSTRIAL CO., LTD.**

Add: RM#1805, East Wing, TianAn Hi-tech Plaza Phase2, TianAn Cyber Park Shenzhen, China  
Tel: (86) 755 88352809 88352810 Fax: (86) 755 88353718 88352499  
E-mail: [jolly@q-crystal.com](mailto:jolly@q-crystal.com) HTTP://[www.q-crystal.com](http://www.q-crystal.com)

# Specifications of Temperature Control Oscillator

## Series6T3, SEAM SEALED CERAMIC 3.2 X 2.5MM Surface Mount Package



### FEATURE

- I Device Name TCXO
- I Model Name
- I Nominal Frequency 19.680 MHz
- I Mass 0.026364g max.
- I Absolute Maximum Ratings

### ELECTRICAL SPECIFICATIONS

(TA = -30 ~ +80 ° C, Load=10kΩ//10pF, VCC=+2.8V, unless otherwise noted)

	Item	Conditions	limits			unit	Note	
			min	Typ	max			
1	Standard Frequency	19.680MHZ						
2	Current Consumption		-	-	2	mA		
3	Output Level		0.8	-	2	Vp-p	1	
4	Symmetry	GND level (DC cut)	40/60	-	60/40	%		
5	Frequency Stability 1.Tolerance	Initial Tolerance(TA=+25° C)	-	-	±2.0	ppm	2	
		After 2 times reflow(TA=+25° C)	-	-	±2.0	ppm	3.6	
	2.vs Temperature	TA=-30 ~ +85 ° C	-	-	±1.5	ppm	4	
	3 3.vs Slope		-	-	±0.1	ppm/° C	5	
	4.vs Supply Voltage	VCC=+2.8V	-	-	±0.2	ppm		
	5..vs Load Variation	Load=(10kΩ//10pF)±10%	-	-	±0.2	ppm		
	6. Vs Aging	TA=Room ambient	-	-	±1.0	ppm/year		
6	Short term stability	Tau=1s	-	-	1.0	ppb		
7	Start Up	@90% of final Vout level	-	-	2.0	ms		
8	Phase Noise	Relative to F0 level Offset 1Hz	-	-	-57	dBc/Hz		
		Relative to F0 level Offset 10Hz	-	-	-85	dBc/Hz		
		Relative to F0 level Offset 100Hz	-	-	-110	dBc/Hz		
		Relative to F0 level Offset 1kHz	-	-	-130	dBc/Hz		
		Relative to F0 level Offset 10kHz	-	-	-140	dBc/Hz		
9	Operable Temperature Range		-30		70		° C	

- Notes: 1. Clipped sine wave (DC-coupled)  
 2. Ref. to Nominal Frequency.  
 3. Please leave after reflow in 2-hour or more at room ambient.  
 4. Ref. to Frequency (TA=+25 ° C)  
 5. 1 Frequency reading for every 2° C  
 6. Ref. to Frequency (Before Reflow)

Add: RM#1805, East Wing, TianAn Hi-tech Plaza Phase2, TianAn Cyber Park Shenzhen, China  
 Tel: (86) 755 88352809 88352810 Fax: (86) 755 88353718 88352499  
 E-mail: [jolly@q-crystal.com](mailto:jolly@q-crystal.com) HTTP://[www.q-crystal.com](http://www.q-crystal.com)

# Specifications of Temperature Control Oscillator

## Series6T3, SEAM SEALED CERAMIC 3.2 X 2.5MM Surface Mount Package



### MARKING AND DIMENSIONS

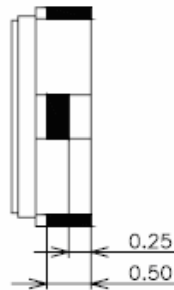
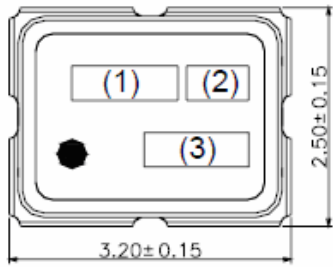

#### Pin Connections

Pin No.	Connection
#1	GND
#2	GND
#3	OUTPUT
#4	Vcc

#### Marking

- (1) Frequency
- (2) Model code
- (3) EIA Date code

Unit: [mm]

Dimensional Tolerance:  $\pm 0.15$   
(Unless otherwise noted)

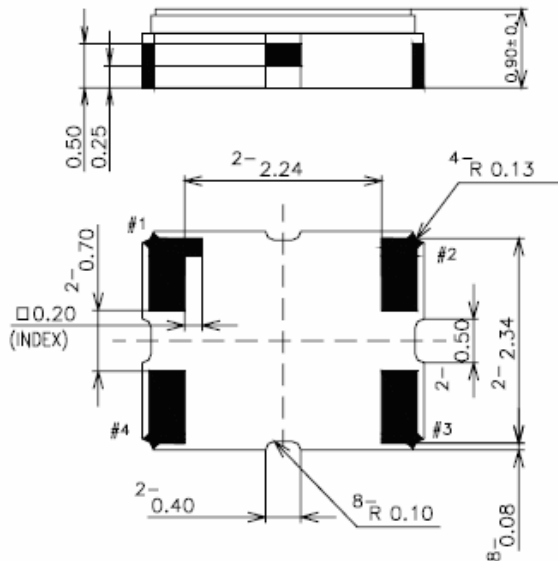

### Measurement Circuit

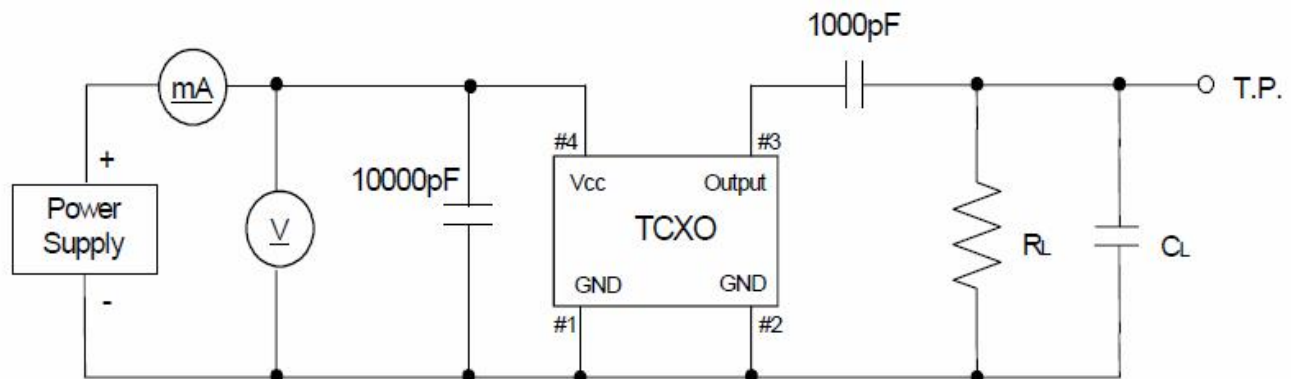

$R_L = 10k\Omega$

$C_L = 10pF$  (Include Jig stray capacitance)

Add: RM#1805, East Wing, TianAn Hi-tech Plaza Phase2, TianAn Cyber Park Shenzhen, China  
 Tel: (86) 755 88352809 88352810 Fax: (86) 755 88353718 88352499  
 E-mail: [jolly@q-crystal.com](mailto:jolly@q-crystal.com) HTTP://[www.q-crystal.com](http://www.q-crystal.com)

# Specifications of Temperature Control Oscillator

## Series6T3, SEAM SEALED CERAMIC 3.2 X 2.5MM Surface Mount Package



### Flatness of Terminal

When the component is placed on the flat surface, the gap from the connecting terminal shall not exceed 0.05 mm.

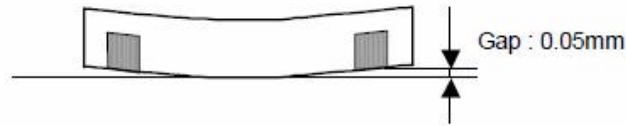

### Reflow Profile

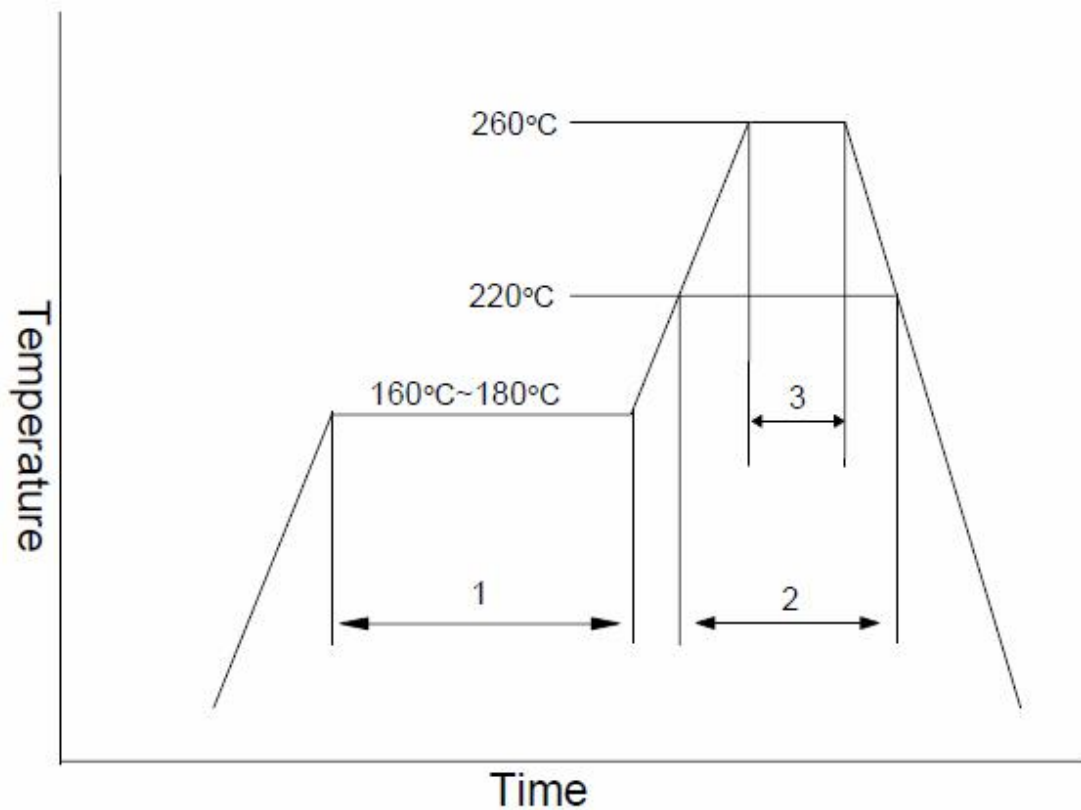

1	Preheat	160~180°C	120s
2	Primary Heat	220°C	60s
3	Peak	260°C	10s max.

Add: RM#1805, East Wing, TianAn Hi-tech Plaza Phase2, TianAn Cyber Park Shenzhen, China  
 Tel: (86) 755 88352809 88352810 Fax: (86) 755 88353718 88352499  
 E-mail: [jolly@q-crystal.com](mailto:jolly@q-crystal.com) HTTP://[www.q-crystal.com](http://www.q-crystal.com)

# Specifications of Temperature Control Oscillator

## Series6T3, SEAM SEALED CERAMIC 3.2 X 2.5MM Surface Mount Package

### Land Pattern Layout(Example)

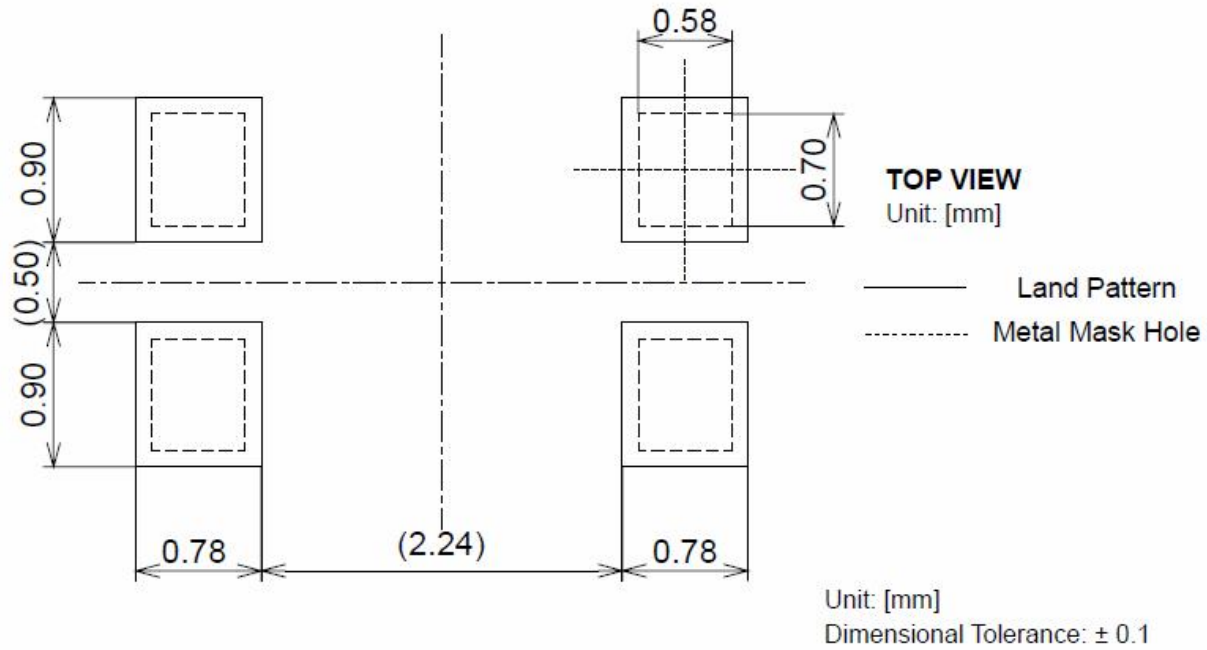

## PACKING

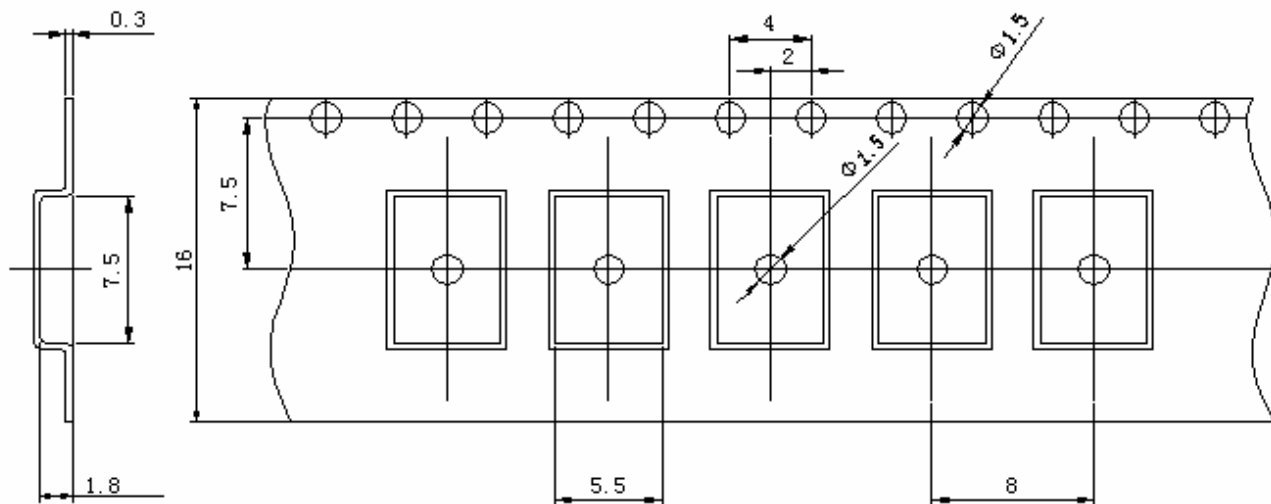

Add: RM#1805, East Wing, TianAn Hi-tech Plaza Phase2, TianAn Cyber Park Shenzhen, China  
 Tel: (86) 755 88352809 88352810 Fax: (86) 755 88353718 88352499  
 E-mail: [jolly@q-crystal.com](mailto:jolly@q-crystal.com) HTTP://[www.q-crystal.com](http://www.q-crystal.com)

# Specifications of Temperature Control Oscillator

## Series6T3, SEAM SEALED CERAMIC 3.2 X 2.5MM Surface Mount Package

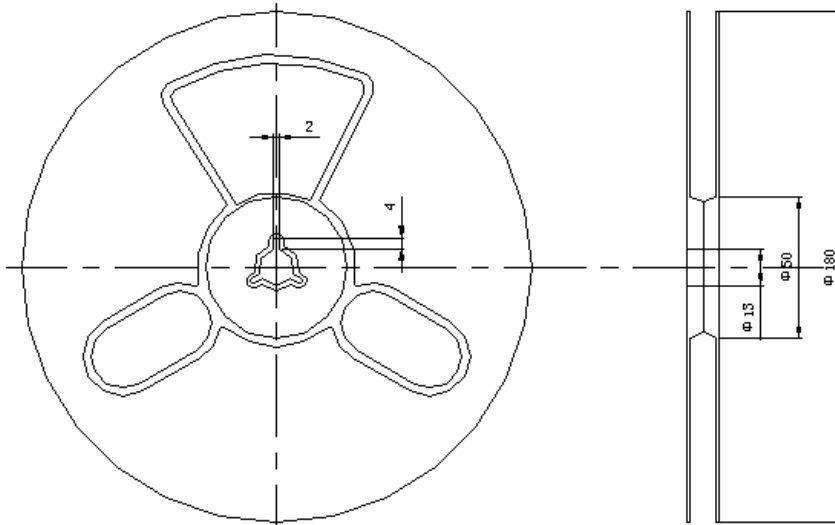

### PART NUMBERING

SJK-	6T3	19.680	2.0	G
		Frequency 19.680: 19.680 MHz	Frequency tolerance e.g. 2.0:±2.0ppm	Operating Temperature A: -10-60°C B: -20-70°C C: -40-85°C D: -30-70°C E: -45-85°C F: -30-80°C G: -30-85°C

### RELIABILITY TEST SPECIFICATION

Test item	Equipment	Condition	Specification
1. SOLDERABILITY TEST	SJK-RELO01、RC-328A	1.solderability:235±5°C, 5±0.5S 2.heat resistance:260±5°C,10±1S restoration of 1 hour	MIL-STD-883E Method 2003.7
2. HERMETICITY TEST	HELIOT-306S	FC-84 FLUOROCARBON, BUBBLE MACHINE	MIL-STD-883E Method 1014.10
3. VIBRATION TEST	HG-V4、 S&A 250B	Enable Crystal (10g) from 0-500Hz, X、Y、Z horizontal, 1 Minute vibration/time, 1time/ 2 hours.	MIL-STD-883E Method 2007.3

Add: RM#1805, East Wing, TianAn Hi-tech Plaza Phase2, TianAn Cyber Park Shenzhen, China  
 Tel: (86) 755 88352809 88352810 Fax: (86) 755 88353718 88352499  
 E-mail: [jolly@q-crystal.com](mailto:jolly@q-crystal.com) HTTP://[www.q-crystal.com](http://www.q-crystal.com)

# Specifications of Temperature Control Oscillator

## Series6T3, SEAM SEALED CERAMIC 3.2 X 2.5MM Surface Mount Package



4. MECHANICAL SHOCK	HPC-200、S&A 250B	Enable Crystal 50G(490m/s <sup>2</sup> ) time=11 ms speed=3.4 m/s half sine wave oscillation	JIS C6701
5. DROP TEST	HARD BOARD. S&A250B	100CM HIGH, 3 TIMES ON HARD BOARD	MIL-STD-202F Method 213B
6. SALT SPRAY	H-SST-60、RC-328A	5% NaCl, 35°C±2°C CHAMBER, 48 hrs., PH: 6.5~7.2	JIS C6701
7. HIGH&LOW TEMP STORAGE TEST(Static test)	H-PTH-80CK & HM101-3ABN, S&A 350B/250B	High temperature: 125°C±2°C, 96hr; Low temperature: -40°C±3°C, 96hrs	MIL-STD-883C, METHOD 1011.8
8. TEMP & HUM CYCLING TEST	H-PTH-80CK CHAMBE , S&A 350B/250B	Temperature: -10°C±2°C ~ 65°C±2°C, Humidity: 93±3%, 1 cycle need 24 hrs. 5cycles.	MIL-STD-883E Method 1005.8
9. HIGH TEM. & HUM. STORAGE TEST	H-PTH-80CK CHAMBE , S&A350B/250B	temperature: 40°C±2 , Humidity: 85+3, -2%, Store 96 hrs	JIS C6701
10. AGING TEST	H-PTH-80CK CHAMBE , S&A350B/250	temperature: 85°C±2, 720hrs	JIS C5023

### Notes on mounting and handling

#### 1. Storage environment

- (1) The temperature and humidity of a storage place, Please give +5 ~ +40°C and 40 ~ 85% as a standard.
- (2) Please use this product within one year from the packing label date of issue.
- (3) Please avoid the place which generates corrosive gas, and the place with much dirt.
- (4) Please keep it in a place with little temperature change.

Dew condensation arises owing to a rapid temperature change and solderability becomes bad.

#### 2. Be cautions to static electricity and high voltage.

3. This product has sufficient durability to fall and vibration. However, conditions may change to the fall after mounting to a PWB, and vibration. When you should drop on a floor the PWB which mounted the product or too

much shock is added. Please use after a performance check.

4. Please check that the curvature of the substrate at the time of substrate cutting does not affect a product. Moreover, especially when a product is near the position of a PWB guide pin, and the position of a PWB break, be careful.

5. The part concerned does not correspond to washing.

6. Please repair at 260°C in 10s with hot air or 350°C in 5s with solder Iron.

Add: RM#1805, East Wing, TianAn Hi-tech Plaza Phase2, TianAn Cyber Park Shenzhen, China

Tel: (86) 755 88352809 88352810 Fax: (86) 755 88353718 88352499

E-mail: [jolly@q-crystal.com](mailto:jolly@q-crystal.com) HTTP://[www.q-crystal.com](http://www.q-crystal.com)