



浙江佳龙电子有限公司

ZHEJIANG JIALONG ELECTRON CO.,LTD

Customer 客户: \_\_\_\_\_

Your part No. 客户号: \_\_\_\_\_

Date 日期: \_\_\_\_\_

## SPECIFICATION 规格书

Product names/产品名称: 轻触开关TACT SWITCH

Product model/型号: TC-1212A

Sample No/样品数量: \_\_\_\_\_

Approval signature 客户签章:

By Date/日期:

Please confirm and sign back



JL R&D Department		
Approved 林强	Checked 浙江籍	Desinged 尤心达

Add/地址: Qianshi Industrial Zone, Yongjia, Wenzhou, Zhejiang

浙江省温州市永嘉县千石工业区

Tel/电话: 86-577-67288055 67288056 Fax/传真: 86-577-67288058

E-mail/邮箱: [jialong@calonsw.com](mailto:jialong@calonsw.com) Web/网站: [www.calonsw.com](http://www.calonsw.com)



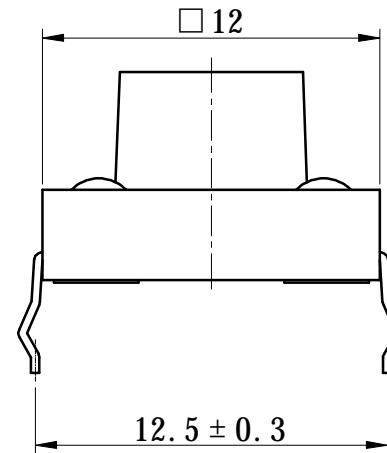
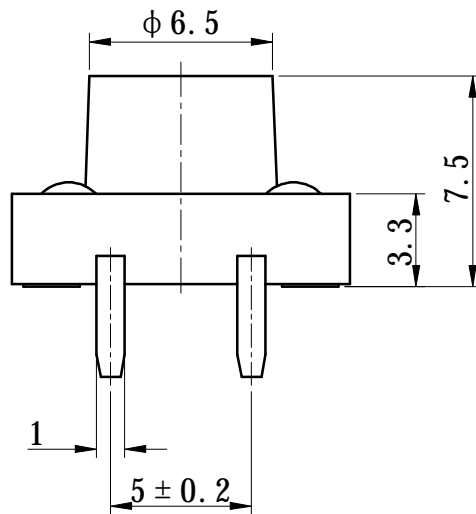

PCB线路板设计参考尺寸  
P. C. B. LAYOUT

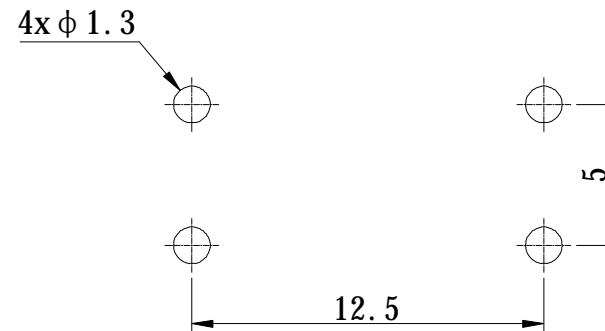

Specifications	
Rating	0.05A 12VDC
Environment Temperature	-25°C ~ 85°C
Contact Resistance	$\leq 50m\Omega$
Insulation Resistance	$\geq 100M\Omega$ (at 500VDC)
Voltage proof	Terminal-terminal 100V AC/10mA/5s
	Terminal-knob 500V AC/10mA/5s
Electronical life	100000 Cycles
Operating Force	250gf

Tolerance:  
 $x. \pm 0.30$  .  $x \pm 0.20$  .  $xx \pm 0.10$   $\angle \pm 2^\circ$  .

						 <b>浙江佳龙电子有限公司</b> <b>ZHEJIANG JIALONG ELECTRON CO., LTD</b>		
标记	处数	说明或更改文件号	签名	日期	单位	mm	产品类型	轻触开关
设计		尤心达	版本	01	Unit	4:1	Product Type	TACT SWITCH
审核		施江缙	阶段标记	量产	比例	A4	Product Model	TC-1212A H7.5
批准		林强	日期	2021.11.17	图幅		图号	
Approve			Date		Sheet	1/1	DWG No	